

EDKRBG018R
13474656



L-force *Drives*

Montageanleitung

Mounting Instructions

Instructions de montage

Instrucciones para el montaje

Istruzioni per il montaggio

ERB

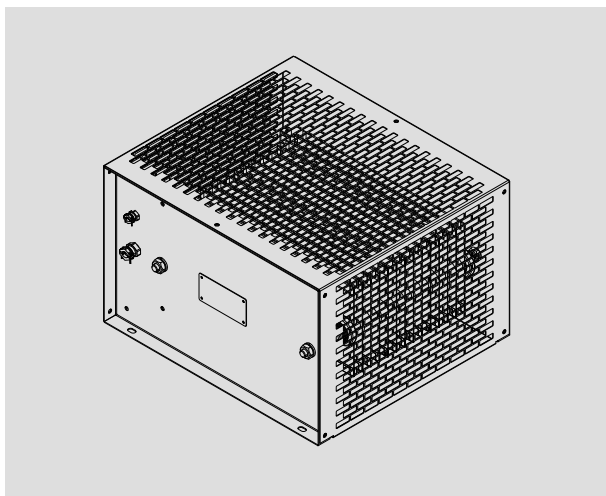

ERBGxxxxxxxx

Bremswiderstand

Brake resistor

Résistance de freinage

Resistencia de frenado

Resistenza di frenatura

Lenze



Lesen Sie zuerst diese Anleitung und die Dokumentation zum Grundgerät, bevor Sie mit den Arbeiten beginnen!
Beachten Sie die enthaltenen Sicherheitshinweise.



Please read these instructions and the documentation of the standard device before you start working!
Observe the safety instructions given therein!



Lire le présent fascicule et la documentation relative à l'appareil de base avant toute manipulation de l'équipement !
Respecter les consignes de sécurité fournies.



Lea estas instrucciones y la documentación del equipo básico antes de empezar a trabajar.
Observe las instrucciones de seguridad indicadas.



Prima di iniziare qualsiasi intervento, leggere le presenti istruzioni e la documentazione relativa al dispositivo di base.
Osservare le note di sicurezza.

1	Über diese Dokumentation	4
1.1	Informationen zur Gültigkeit	4
1.2	Zielgruppe	4
1.3	Dokumenthistorie	4
1.4	Verwendete Konventionen	5
1.5	Verwendete Hinweise	6
2	Sicherheitshinweise	8
2.1	Allgemeine Sicherheitshinweise	8
2.2	Restgefahren	9
3	Produktbeschreibung	12
3.1	Übersicht	12
3.2	Identifikation	13
3.3	Bestimmungsgemäße Verwendung	14
3.4	Auslegungsbedingungen	15
4	Technische Daten	17
4.1	Allgemeine Daten und Einsatzbedingungen	17
4.2	Bemessungsdaten	19
4.3	Mechanische Daten	20
5	Mechanische Installation	22
5.1	Montageschritte	22
6	Elektrische Installation	23
6.1	Wichtige Hinweise	23
6.2	Anschlussdaten	23
6.3	Anschlussplan	24
6.4	Montageschritte	25
7	Wartung	27
7.1	Wartungsintervalle	27
7.2	Wartungsarbeiten	27

1 Über diese Dokumentation

Informationen zur Gültigkeit

1 Über diese Dokumentation

1.1 Informationen zur Gültigkeit

Diese Anleitung ist gültig für

- ▶ Bremswiderstände ERBGxxxxxxxx

1.2 Zielgruppe

Diese Dokumentation richtet sich an qualifiziertes Fachpersonal nach IEC 60364.

Qualifiziertes Fachpersonal sind Personen, die für die auszuführenden Tätigkeiten bei der Aufstellung, Montage, Inbetriebsetzung und dem Betrieb des Produkts über entsprechende Qualifikationen verfügen.



Tipp!





Informationen und Hilfsmittel rund um die Lenze-Produkte finden Sie im Download-Bereich unter

www.lenze.com

1.3 Dokumenthistorie

Materialnummer	Version			Beschreibung
13474656	8.0	10/2014	TD29	UL-Hinweise in französischer Sprache für Canada EAC-Konformität allgemeine Korrekturen
13314940	7.0	01/2011	TD29	Überarbeitung

1.4 Verwendete Konventionen

Informationsart	Auszeichnung	Beispiele/Hinweise
Zahlenschreibweise		
Dezimaltrennzeichen	Punkt	Es wird generell der Dezimalpunkt verwendet. Zum Beispiel: 1234.56
Warnhinweise		
UL-Warnhinweise		Werden in englischer und französischer Sprache verwendet.
UR-Warnhinweise		
Textauszeichnung		
Programmname	» «	PC-Software Zum Beispiel: »Engineer«, »Global Drive Control« (GDC)
Symbole		
Seitenverweis		Verweis auf eine andere Seite mit zusätzlichen Informationen Zum Beispiel:  16 = siehe Seite 16
Dokumentationsverweis		Verweis auf eine andere Dokumentation mit zusätzlichen Informationen Zum Beispiel:  EDKxxx = siehe Dokumentation EDKxxx





1 Über diese Dokumentation

Verwendete Hinweise



1.5 **Verwendete Hinweise**
Um auf Gefahren und wichtige Informationen hinzuweisen, werden in dieser Dokumentation folgende Piktogramme und Signalwörter verwendet:

Sicherheitshinweise



Aufbau der Sicherheitshinweise:

	Gefahr! (kennzeichnet die Art und die Schwere der Gefahr) Hinweistext (beschreibt die Gefahr und gibt Hinweise, wie sie vermieden werden kann)
Piktogramm und Signalwort	Bedeutung
	Gefahr! Gefahr von Personenschäden durch gefährliche elektrische Spannung Hinweis auf eine unmittelbar drohende Gefahr, die den Tod oder schwere Verletzungen zur Folge haben kann, wenn nicht die entsprechenden Maßnahmen getroffen werden.
	Gefahr! Gefahr von Personenschäden durch eine allgemeine Gefahrenquelle Hinweis auf eine unmittelbar drohende Gefahr, die den Tod oder schwere Verletzungen zur Folge haben kann, wenn nicht die entsprechenden Maßnahmen getroffen werden.
	Stop! Gefahr von Sachschäden Hinweis auf eine mögliche Gefahr, die Sachschäden zur Folge haben kann, wenn nicht die entsprechenden Maßnahmen getroffen werden.

Anwendungshinweise

Piktogramm und Signalwort	Bedeutung
	Hinweis! Wichtiger Hinweis für die störungsfreie Funktion
	Tipp! Nützlicher Tipp für die einfache Handhabung
	Verweis auf andere Dokumentation

Spezielle Sicherheitshinweise und Anwendungshinweise für UL und UR

Piktogramm und Signalwort	Bedeutung
 Warnings!	Sicherheitshinweis oder Anwendungshinweis für den Betrieb eines UL-approbierten Geräts in UL-approbierten Anlagen. Möglicherweise wird das Antriebssystem nicht UL-gerecht betrieben, wenn nicht die entsprechenden Maßnahmen getroffen werden.
 Warnings!	Sicherheitshinweis oder Anwendungshinweis für den Betrieb eines UR-approbierten Geräts in UL-approbierten Anlagen. Möglicherweise wird das Antriebssystem nicht UL-gerecht betrieben, wenn nicht die entsprechenden Maßnahmen getroffen werden.

2 Sicherheitshinweise

2.1 Allgemeine Sicherheitshinweise



Gefahr!

Wenn Sie die folgenden grundlegenden Sicherheitsmaßnahmen missachten, kann dies zu schweren Personenschäden und Sachschäden führen:

- ▶ Lenze-Antriebs- und Automatisierungskomponenten ...
 - ... ausschließlich bestimmungsgemäß verwenden.
 - ... niemals trotz erkennbarer Schäden in Betrieb nehmen.
 - ... niemals technisch verändern.
 - ... niemals unvollständig montiert in Betrieb nehmen.
 - ... niemals ohne erforderliche Abdeckungen betreiben.
 - ... können während und nach dem Betrieb - ihrer Schutzart entsprechend - spannungsführende, auch bewegliche oder rotierende Teile haben. Oberflächen können heiß sein.
- ▶ Alle Vorgaben der beiliegenden und zugehörigen Dokumentation beachten.

Dies ist Voraussetzung für einen sicheren und störungsfreien Betrieb sowie für das Erreichen der angegebenen Produkteigenschaften.

Die in diesem Dokument dargestellten verfahrenstechnischen Hinweise und Schaltungsausschnitte sind Vorschläge, deren Übertragbarkeit auf die jeweilige Anwendung überprüft werden muss. Für die Eignung der angegebenen Verfahren und Schaltungsvorschläge übernimmt der Hersteller keine Gewähr.
- ▶ Alle Arbeiten mit und an Lenze-Antriebs- und Automatisierungskomponenten darf nur qualifiziertes Fachpersonal ausführen.

Nach IEC 60364 bzw. CENELEC HD 384 sind dies Personen, ...

 - ... die mit Aufstellung, Montage, Inbetriebsetzung und Betrieb des Produkts vertraut sind.
 - ... die über die entsprechenden Qualifikationen für ihre Tätigkeit verfügen.
 - ... die alle am Einsatzort geltenden Unfallverhütungsvorschriften, Richtlinien und Gesetze kennen und anwenden können.

2.2 Restgefahren



Gefahr!

Gefährliche elektrische Spannung

Während des Betriebs des Grundgeräts und **bis zu 3 Minuten nach dem Netzabschalten** können an den Anschlüssen des Bremswiderstands gefährliche elektrische Spannungen anliegen.

Mögliche Folgen:

- ▶ Tod oder schwere Verletzungen beim Berühren der Anschlussklemmen.

Schutzmaßnahmen:

- ▶ Vor allen Arbeiten am Bremswiderstand das Grundgerät vom Netz trennen.
- ▶ Alle Leistungsklemmen auf Spannungsfreiheit prüfen.
- ▶ Den Montageort so wählen, dass die in den Technischen Daten genannten Einsatzbedingungen immer gewährleistet sind.



Gefahr!

Heiße Oberfläche während des Betriebs

Der Bremswiderstand wird während des Betriebs sehr heiß. (Temperaturen siehe Technische Daten.)

Mögliche Folgen:

- ▶ Schwere Verbrennungen beim Berühren des Bremswiderstands.
- ▶ Feuer oder Schwelbrand, wenn sich brennbare Materialien oder Stoffe in der Nähe des Bremswiderstands befinden oder dorthin gelangen können.

Schutzmaßnahmen:

- ▶ Vor Arbeiten am Bremswiderstand dessen Oberflächentemperatur prüfen.
- ▶ Den Montageort so wählen, dass die in den Technischen Daten genannten Einsatzbedingungen immer gewährleistet sind.
- ▶ Den Montageort durch geeignete Brandschutzmaßnahmen und einen Berührungsschutz sichern.

**Stop!****Mögliche Überhitzung des Bremswiderstands während des Betriebs**

Durch ungenügende Wärmeabfuhr kann der Bremswiderstand während des Betriebs überhitzen.

Mögliche Folgen:

- ▶ Der Bremswiderstand wird zerstört.
- ▶ Der Antrieb wird nicht abgebremst sondern trudelt aus.

Schutzmaßnahmen:

- ▶ Den Thermokontakt des Bremswiderstands immer anschließen.
- ▶ Den Thermokontakt so in die Anlagenüberwachung einbinden, dass bei Überhitzung des Bremswiderstands die Netzversorgung des Grundgerätes abgeschaltet wird (z. B. die Netzschutz-Ansteuerung abschalten).



Warnings!

Conditions of Acceptability:

- ▶ The product covered by this report is intended for use with Power Conversion Equipment and the like.
- ▶ The devices were tested for horizontal mounting positions. If other mounting positions are necessary in the end use applications, a temperature test shall be performed to ensure the maximum allowed temperature rise.
- ▶ These devices are intended for factory wiring only. The cable lug connector shall be mounted direct on the surface of the copper busbar to provide appropriate connection.
- ▶ Temperature tests have been conducted for continuous duty as indicated in the rating table with closed bottom surface. The heat capability and the maximum temperature rise for higher current ratings at shorter duty cycles shall be determined in the end use.
- ▶ The device were evaluated related to spacings according UL508. The appropriate spacings has to be determined in the end use application. The maximum Voltage rating each element could be max. 1000 V Ac. Therefore the spacing related to UL508 have to be 601-1000 V 14 mm through air and 25.4 mm over surface.
- ▶ The temperature rating of the connection cable shall be at least 105 °C to ensure proper connection.
- ▶ The required wire bending space and the spacings at the terminals after connection shall be determined in the end use application.

3 Produktbeschreibung

Übersicht

3 Produktbeschreibung

3.1 Übersicht

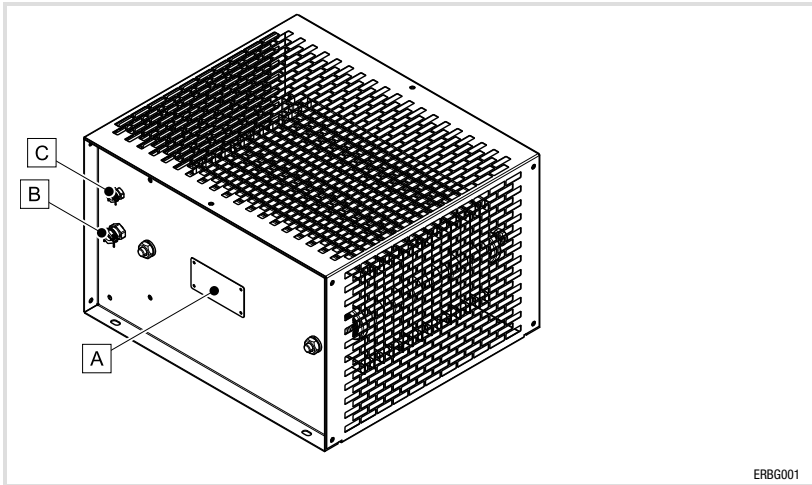

Lieferumfang

Pos.	Beschreibung
	Bremswiderstand
	Montageanleitung

Elemente am Bremswiderstand

Pos.	Beschreibung
A	Typenschild
B	Kabelverschraubung Bremswiderstand-Leitung
C	Kabelverschraubung Thermokontakt-Leitung

3.2 Identifikation

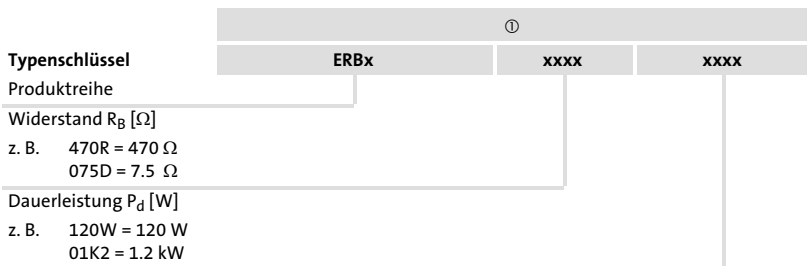
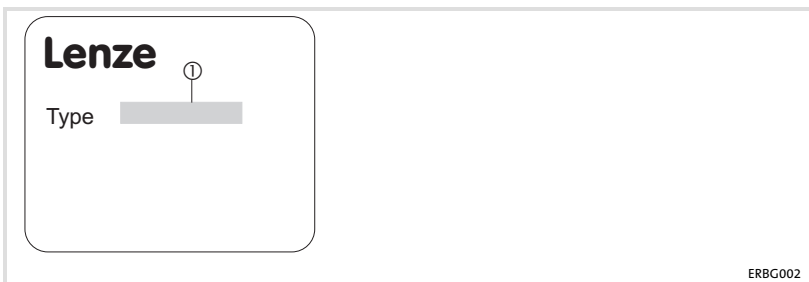

Bestimmungsgemäße Verwendung

Bremswiderstände

- ▶ nur unter den in dieser Betriebsanleitung vorgeschriebenen Einsatzbedingungen betreiben.
- ▶ sind Komponenten
 - zum Einbau in eine Maschine.
 - zum Zusammenbau mit anderen Komponenten zu einer Maschine.

Die Inbetriebnahme des Bremswiderstands ist solange untersagt, bis festgestellt wurde, dass die Maschine, in welche der Bremswiderstand eingebaut werden soll, den Bestimmungen der EG-Maschinenrichtlinie entsprechen.

- ▶ sind elektrische Betriebsmittel zum Einbau in Schaltschränke oder ähnliche abgeschlossene Betriebsräume.
- ▶ erfüllen die Schutzanforderungen der EG-Richtlinie "Niederspannung".
- ▶ sind keine Maschinen im Sinne der EG-Richtlinie Maschinen.
- ▶ sind keine Haushaltsgeräte, sondern als Komponenten ausschließlich für die Weiterverwendung zur gewerblichen Nutzung bestimmt.

Antriebssysteme mit Bremswiderständen

- ▶ Die Verantwortung für die Einhaltung der EG-Richtlinien in der Maschinenanwendung liegt beim Weiterverwender.

Jede andere Verwendung gilt als sachwidrig!

3.4 Auslegungsbedingungen

Beim Einsatz von Bremswiderständen beachten:

- ▶ Mittelwert der generatorischen Leistung < Dauerleistung P_d des Bremswiderstands.
- ▶ Generatorische Leistung während der Bremszeit < Wärmemenge Q_B des Bremswiderstands.
- ▶ Bremszeit < 10 % der Zykluszeit (Bremszeit + Pausenzeit).
- ▶ Thermokontakt immer anschließen und so in die Anlagenüberwachung einbinden, dass bei Überhitzung des Bremswiderstands die Netzversorgung des Grundgeräts abgeschaltet wird.

Zu jedem Zeitpunkt muss gelten: Im Zeitintervall $t_{cyc, RB}$ (Bremswiderstandzyklus) müssen die kumulierten Bremszeiten t_{brk} immer \leq der maximalen Bremsdauer $t_{brk, max}$ sein.

Berechnung

Bremswiderstand-Zyklus $t_{cyc, RB}$:

$$t_{cyc, RB} = \frac{Q_B}{P_d} \text{ mit}$$

Q_B Wärmemenge in Ws
 P_d Dauerleistung in W

Max. Bremsdauer $t_{brk, max}$ innerhalb des Zeitintervalls $t_{cyc, RB}$:

$$t_{brk, max} = \frac{Q_B \cdot R_B}{U_{max}^2} \text{ mit}$$

Q_B Wärmemenge in Ws
 R_B Widerstand in Ω
 U_{max} Max. Betriebsspannung in V

Beispiele für die Auswertung der Bedingung

Gegeben ist der Bremswiderstandzyklus $t_{\text{cyc, RB}} = 150 \text{ s}$ und die max. Bremsdauer $t_{\text{brk, max}} = 10 \text{ s}$. Die Bremszeiten t_{brk} und der Prozesszyklus $t_{\text{cyc, PrC}}$ sind beispielhaft.

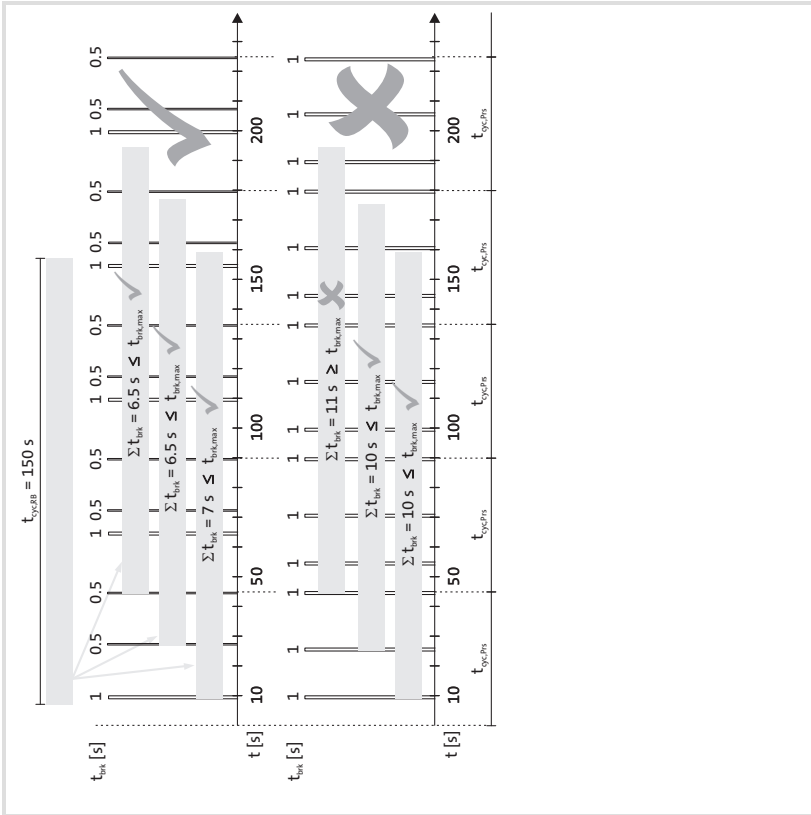

Im oberen Beispiel wird die Auslegungsbedingung zu jedem Zeitpunkt eingehalten. Im unteren Beispiel wird die Auslegungsbedingungen einmal nicht eingehalten, das heißt, der gewählte Bremswiderstand ist für den vorgegebenen Prozess nicht geeignet. Setzen Sie einen Bremswiderstand mit größerer Leistung (kürzerem Bremswiderstandzyklus $t_{\text{cyc, RB}}$) ein.

4 Technische Daten

4.1 Allgemeine Daten und Einsatzbedingungen

Konformität und Approbation

Konformität

CE	2006/95/EG	Niederspannungsrichtlinie	
EAC	TP TC 020/2011 (TR ZU 020/2011)	Elektromagnetische Verträglichkeit von technischen Erzeugnis- sen	Eurasische Konformität TR ZU: Technische Regulie- rung der Zollunion
EAC	TP TC 004/2011 (TR ZU 004/2011)	Über die Sicherheit von Niederspannungsaus- rüstung	Eurasische Konformität TR ZU: Technische Regulie- rung der Zollunion

Approbation

UR	UL508	Industrial Control Equipment, Underwriter Laborato- ries (File-No. E221095) for USA and Canada
----	-------	---

Personenschutz und Geräteschutz

Schutzart	EN 60529	IP20	
	NEMA 250	Berührschutz nach Typ 1	
Thermokontakt			
Ausführung		Öffner, 100 °C	
Schaltleistung		250 V AC / 2.5 A 110 V AC / 1.6 A	

Umweltbedingungen

Klima

Lagerung	IEC/EN 60721-3-1	1K3 (-25 ... +60 °C)
Transport	IEC/EN 60721-3-2	2K3 (-25 ... +70 °C)
Betrieb	IEC/EN 60721-3-3	3K3 (-10 ... +55 °C) Stromreduzierung von +45 ... +55 °C: 1 %/°C
Aufstellhöhe		0 ... 4000 m üNN 1000 ... 4000 m üNN: Stromreduzierung 5 %/1000 m
Rüttelfestigkeit (9.81 m/s ² = 1 g)	EN 50178, IEC 61800-5-1, Germanischer Lloyd, allgemeine Bedingungen	Beschleunigungsfest bis 0.7 g

Montagebedingungen		
Montageort		<ul style="list-style-type: none"> • Der Montageort muss den in den "Allgemeinen Daten" genannten Geräteeigenschaften entsprechen. • Brennbare Materialien oder Stoffe dürfen sich nicht in der Nähe des Bremswiderstands befinden. • Die vom Bremswiderstand erzeugte Wärme muss ungehindert abgeführt werden.
Einbaulage		
Standard		Horizontal-stehend
Variante		Vertikal-hängend mit Anschlussleitungen unten.
Einbaufreiräume		
Standard		Oben > 200 mm Seitlich > 100 mm
Variante		Oben > 200 mm Seitlich > 100 mm Unten > 300 mm

4.2 Bemessungsdaten

Elektrische Daten				
	R_B	P_d	Q_B	U_{max}
	[Ω]	[W]	[kW _s]	[V _{DC}]
ERBG023D05K6	2.3	5600	840	1000
ERBG028D04K1	2.8	4100	615	
ERBG035D03K3	3.5	3300	495	
ERBG043D03K0	4.3	3000	450	
ERBG005R02K6	5.0	2600	390	
ERBG075D01K9	7.5	1900	285	
ERBG012R01K9	12.0			
ERBG012R05K2		5200	780	
ERBG015R03K3	15.0	3300	495	
ERBG015R06K2		6200	930	
ERBG015R10K0		10000	1500	
ERBG018R04K3		18.0	4300	

- R_B Widerstand
- P_d Dauerleistung
- Q_B Wärmemenge
- U_{max} Max. Betriebsspannung

Temperaturen			
	T_{nom}	T_{TK}	T_{max}
		[°C]	
Innen	390	530	690
Am Gehäuse	200	240	300
An der Einbaufreirraumgrenze*)	120	160	200

- T_{nom} Maximale Temperatur bei Bemessungsdaten
- T_{TK} Temperatur bei der der Thermokontakt auslöst
- T_{max} Maximale Temperatur bei sachwidriger Verwendung
- *) Gemessen bei Umgebungsmedium Luft (kleine Wärmeleitfähigkeit); wenn sich Materialien/Stoffe an der Einbaufreirraumgrenze befinden, die sich aufheizen (größere Wärmeleitfähigkeit), steigt die Temperatur weiter an.

4.3 Mechanische Daten

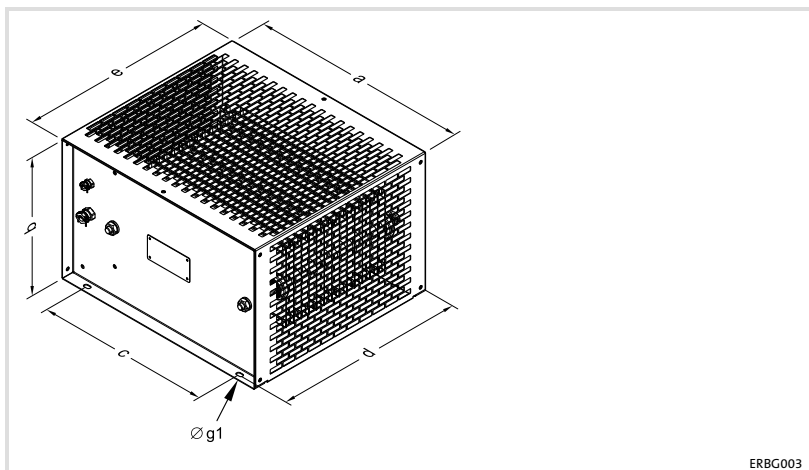

	a	b	c	d	e	g1	
	[mm]						[kg]
ERBG023D05K6	486	302	380	400	426	6.3	15.9
ERBG028D04K1							12.8
ERBG035D03K3							12.6
ERBG043D03K0				300	326		11.8
ERBG005R02K6							11.0
ERBG075D01K9							9.5
ERBG012R01K9				210	236		15.1
ERBG012R05K2							12.6
ERBG015R03K3							17.0
ERBG015R06K2							22.0
ERBG015R10K0							13.5
ERBG018R04K3							400

Einbaufreiräume bei Standardmontage

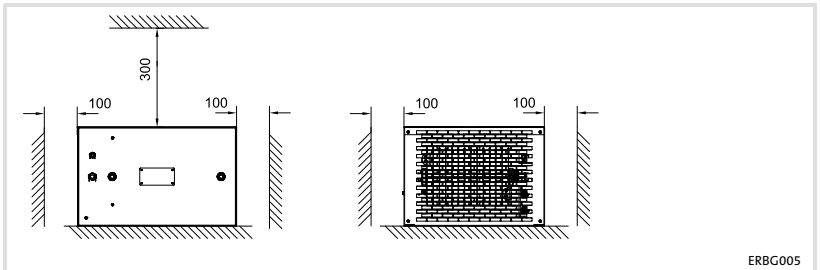

Alle Maße in Millimeter.

Einbaufreiräume bei Montagevariante

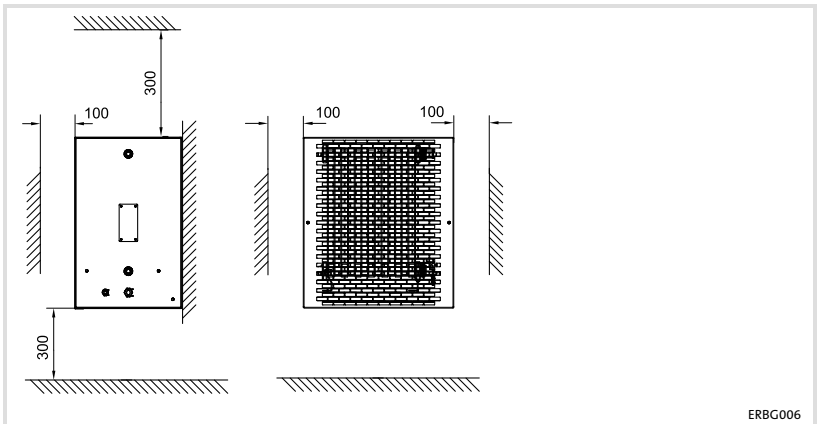

Alle Maße in Millimeter.

5 Mechanische Installation

5.1 Montageschritte

So montieren Sie den Bremswiderstand:

1. Wählen Sie einen geeigneten Montageort.
 - Der Montageort muss die in den Technischen Daten genannten Einsatzbedingungen immer gewährleisten; ggf. zusätzliche Maßnahmen ergreifen.
 - Eine ungehinderte Luftzirkulation zum Abführen der Wärme muss gewährleistet sein.
2. Verschrauben Sie den Bremswiderstand am Montageort.
 - Der Montageort und das Montagematerial muss die mechanische Verbindung dauerhaft gewährleisten.

6 Elektrische Installation

6.1 Wichtige Hinweise



Stop!

Mögliche Überhitzung des Bremswiderstands während des Betriebs

Durch ungenügende Wärmeabfuhr kann der Bremswiderstand während des Betriebs überhitzen.

Mögliche Folgen:

- ▶ Der Bremswiderstand wird zerstört.
- ▶ Der Antrieb wird nicht abgebremst sondern trudelt aus.

Schutzmaßnahmen:

- ▶ Den Thermokontakt des Bremswiderstands immer anschließen.
- ▶ Den Thermokontakt so in die Anlagenüberwachung einbinden, dass bei Überhitzung des Bremswiderstands die Netzversorgung des Grundgerätes abgeschaltet wird (z. B. die Netzschütz-Ansteuerung abschalten).

6.2 Anschlussdaten

Anschluss	Kabelverschraubung	Anschlussart	Anschlussgröße	Anzugsmoment
RB1, RB2 (Bremswiderstand)	M25 / M40 ¹⁾	Bolzenklemme	M6	4 Nm 35.4 lb-in
PE (Schutzleiter)				
T1, T2 (Thermokontakt)	M16	Buchsenklemme	0.75 ... 1.5 mm ² 18 ... 16 AWG	0.32 Nm 2.85 lb-in

¹⁾ ERBG023D05K6, ERBG028D04K1



Tipp!

Der Bremswiderstand hat zwei PE-Anschlüsse; einen innerhalb des Gehäuses und einen außerhalb.

- ▶ Wenn Sie eine Bremswiderstandsleitung mit PE-Leiter verwenden, führen Sie diese durch die Kabelverschraubung und legen den PE-Leiter innen auf.
- ▶ Wenn Sie eine separate PE-Leitung einsetzen, schließen Sie diese außen an.

6.3 Anschlussplan

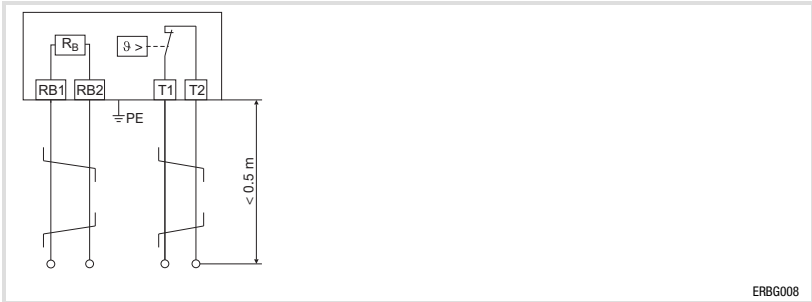

Variante 1 (kurze Leitungen)

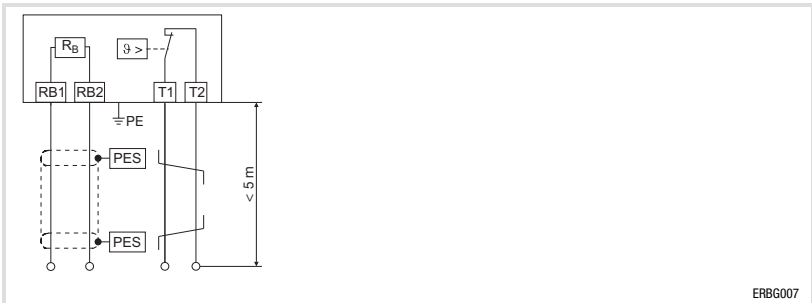

 Verdrillte Leitungen

Variante 2 (lange Leitungen)





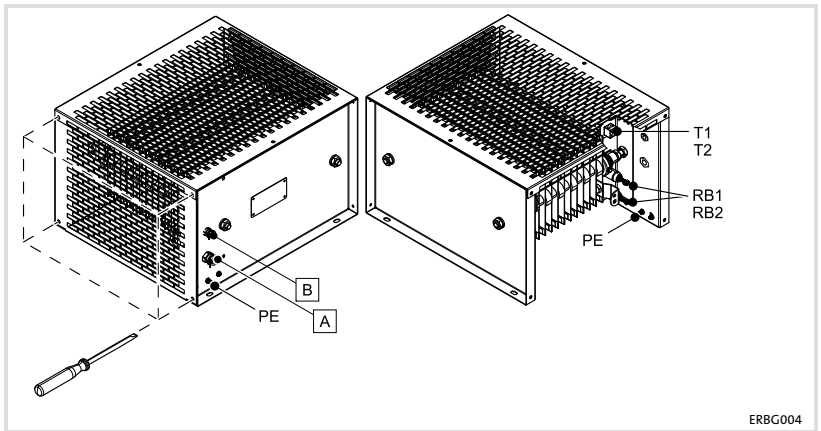

 HF-Schirmabschluss durch großflächige PE-Anbindung
 Verdrillte Leitungen

6.4 Montageschritte



So schließen Sie den Bremswiderstand an:

1. Grundgerät vom Netz trennen und alle Leistungsklemmen auf Spannungsfreiheit prüfen.
2. Klemmenabdeckung demontieren.
3. Bremswiderstand-Leitung auflegen:
 - Bei einer Leitungslänge bis 0.5 m verdrehte Leitung verwenden (Anschlussplan Variante 1).
 - Bei einer Leitungslänge bis 5 m geschirmte Leitung verwenden (Anschlussplan Variante 2).
 - Leitung durch Kabelverschraubung  ziehen.
 - Adern am Bremswiderstand am Anschluss RB1, RB2 und PE auflegen, dabei Anzugsmoment beachten. PE-Anschluss nach EN 61800-5-1 ausführen.
 - Kabelverschraubung  festziehen.
Bei geschirmter Leitung: Der Schirm muss fest und großflächig mit der Kabelverschraubung verbunden sein.
 - Adern und Schirm am Grundgerät auflegen, dabei Dokumentation des Grundgerätes beachten.
4. Thermokontakt-Leitungen auflegen:
 - Verdrehte Leitung verwenden.
 - Leitung durch Kabelverschraubung  ziehen.
 - Adern am Bremswiderstand am Anschluss T1 und T2 auflegen, dabei Anzugsmoment beachten.
 - Kabelverschraubung  festziehen.
 - Den Thermokontakt so in die Anlagenüberwachung einbinden, dass bei Überhitzung des Bremswiderstands die Netzversorgung abgeschaltet wird.
5. Klemmenabdeckung montieren.



Hinweis!

Nach dem ersten Einschalten und evtl. auch nach längerem Nichtgebrauch, kann eine Geruchsbildung verbunden mit einer leichten Rauchentwicklung vom Bremswiderstand ausgehen. Dieses ist unbedenklich.

7 **Wartung**

7.1 **Wartungsintervalle**

Der Bremswiderstand ist wartungsfrei. Trotzdem müssen Sie in regelmäßigen und unter Berücksichtigung der Umgebungsbedingungen ausreichend kurzen Intervallen eine Sichtprüfung durchführen.

Kontrollieren Sie:

- ▶ Entspricht die Umgebung des Bremswiderstands noch den in den Technischen Daten genannten Einsatzbedingungen?
- ▶ Behindert kein Staub oder Schmutz die Wärmeabfuhr des Bremswiderstands?
- ▶ Sind die mechanischen und elektrischen Verbindungen in Ordnung?

7.2 **Wartungsarbeiten**

Bremswiderstand reinigen

1. Grundgerät vom Netz trennen und mindestens 3 Minuten warten.
2. Temperatur des Bremswiderstands prüfen, ggf. abkühlen lassen.
3. Anschlüsse des Bremswiderstands auf Spannungsfreiheit prüfen.
4. Bremswiderstand ohne Reinigungsmittel säubern.



Notizen

1	About this documentation	30
1.1	Validity information	30
1.2	Target group	30
1.3	Document history	30
1.4	Conventions used	31
1.5	Notes used	32
2	Safety instructions	34
2.1	General safety instructions	34
2.2	Residual hazards	35
3	Product description	38
3.1	Overview	38
3.2	Identification	39
3.3	Application as directed	40
3.4	Dimensioning conditions	41
4	Technical data	43
4.1	General data and operating conditions	43
4.2	Rated data	45
4.3	Mechanical data	46
5	Mechanical installation	48
5.1	Mounting steps	48
6	Electrical installation	49
6.1	Important notes	49
6.2	Connection data	49
6.3	Connection plan	50
6.4	Mounting steps	51
7	Maintenance	53
7.1	Maintenance intervals	53
7.2	Maintenance operations	53

1 About this documentation

Validity information

1 About this documentation

1.1 Validity information

These instructions are valid for

- ▶ Brake resistors ERBGxxxxxxx

1.2 Target group

This documentation is directed at qualified skilled personnel according to IEC 60364.

Qualified skilled personnel are persons who have the required qualifications to carry out all activities involved in installing, mounting, commissioning, and operating the product.



Tip!







Information and tools concerning the Lenze products can be found in the download area under

www.lenze.com

1.3 Document history

Material number	Version			Description
13474656	8.0	10/2014	TD29	UL notes in French for Canada EAC Conformity General corrections
13314940	7.0	01/2011	TD29	Revision

1.4 Conventions used

Type of information	Identification	Examples/notes
Spelling of numbers		
Decimal separator	Point	In general, the decimal point is used. For instance: 1234.56
Warnings		
UL warnings		Given in English and French
UR warnings		
Text		
Program name	» «	PC software For example: »Engineer«, »Global Drive Control« (GDC)
Icons		
Page reference		Reference to another page with additional information For instance:  16 = see page 16
Documentation reference		Reference to another documentation with additional information For example:  EDKxxx = see documentation EDKxxx

1 About this documentation

Notes used

1.5 Notes used

The following pictographs and signal words are used in this documentation to indicate dangers and important information:

Safety instructions

Structure of safety instructions:





Danger!



(characterises the type and severity of danger)

Note



(describes the danger and gives information about how to prevent dangerous situations)

Pictograph and signal word	Meaning
 Danger!	Danger of personal injury through dangerous electrical voltage. Reference to an imminent danger that may result in death or serious personal injury if the corresponding measures are not taken.
 Danger!	Danger of personal injury through a general source of danger. Reference to an imminent danger that may result in death or serious personal injury if the corresponding measures are not taken.
 Stop!	Danger of property damage. Reference to a possible danger that may result in property damage if the corresponding measures are not taken.

Application notes

Pictograph and signal word	Meaning
 Note!	Important note to ensure troublefree operation
 Tip!	Useful tip for simple handling
	Reference to another documentation

Special safety instructions and application notes for UL and UR

Pictograph and signal word	Meaning
 Warnings!	Safety or application note for the operation of a UL-approved device in UL-approved systems. Possibly the drive system is not operated in compliance with UL if the corresponding measures are not taken.
 Warnings!	Safety or application note for the operation of a UR-approved device in UL-approved systems. Possibly the drive system is not operated in compliance with UL if the corresponding measures are not taken.

2 Safety instructions

General safety instructions

2 Safety instructions

2.1 General safety instructions



Danger!

Disregarding the following basic safety measures may lead to severe personal injury and damage to material assets!

- ▶ Lenze drive and automation components ...
 - ... must only be used for the intended purpose.
 - ... must never be operated if damaged.
 - ... must never be subjected to technical modifications.
 - ... must never be operated unless completely assembled.
 - ... must never be operated without the covers/guards.
 - ... can - depending on their degree of protection - have live, movable or rotating parts during or after operation. Surfaces can be hot.
- ▶ All specifications of the corresponding enclosed documentation must be observed.

This is vital for a safe and trouble-free operation and for achieving the specified product features.

The procedural notes and circuit details provided in this document are proposals which the user must check for suitability for his application. The manufacturer does not accept any liability for the suitability of the specified procedures and circuit proposals.
- ▶ Only qualified skilled personnel are permitted to work with or on Lenze drive and automation components.

According to IEC 60364 or CENELEC HD 384, these are persons ...

 - ... who are familiar with the installation, assembly, commissioning and operation of the product,
 - ... possess the appropriate qualifications for their work,
 - ... and are acquainted with and can apply all the accident prevent regulations, directives and laws applicable at the place of use.

2.2 Residual hazards



Danger!

Dangerous electrical voltage

The terminals of the brake resistor may carry dangerous voltages during operation of the basic device and **up to three minutes after mains disconnection**.

Possible consequences:

- ▶ Death or severe injuries when touching the terminals.

Protective measures:

- ▶ Before working on the brake resistor disconnect the basic device from the mains.
- ▶ Check all power terminals for safe isolation from supply.
- ▶ Select the mounting location so that the operating conditions mentioned in the technical data are always ensured.



Danger!

Hot surface during operation

During operation, the brake resistor becomes very hot. (For temperatures, see Technical data.)

Possible consequences:

- ▶ Severe burns when touching the brake resistor.
- ▶ Fire or smoldering fire if flammable materials or substances are placed near the brake resistor or may get to it.

Protective measures:

- ▶ Before working on the brake resistor, check its surface temperature.
- ▶ Select the mounting location so that the operating conditions mentioned in the technical data are always ensured.
- ▶ Protect the mounting location by suitable fire prevention and protection against contact.

**Stop!****Possible overheating of the brake resistor during operation**

Inadequate heat dissipation during operation can cause the brake resistor to overheat.

Possible consequences:

- ▶ The brake resistor is destroyed.
- ▶ The drive is not braked but coasts to a standstill.

Protective measures:

- ▶ Always connect the thermal contact of the brake resistor.
- ▶ Integrate the thermal contact into the overall equipment monitoring apparatus in such a way that the supply of power to the standard device is switched off if the brake resistor overheats (e.g. switch-off by means of mains contactor control).



Warnings!

Conditions of Acceptability:

- ▶ The product covered by this report is intended for use with Power Conversion Equipment and the like.
- ▶ The devices were tested for horizontal mounting positions. If other mounting positions are necessary in the end use applications, a temperature test shall be performed to ensure the maximum allowed temperature rise.
- ▶ These devices are intended for factory wiring only. The cable lug connector shall be mounted direct on the surface of the copper busbar to provide appropriate connection.
- ▶ Temperature tests have been conducted for continuous duty as indicated in the rating table with closed bottom surface. The heat capability and the maximum temperature rise for higher current ratings at shorter duty cycles shall be determined in the end use.
- ▶ The device were evaluated related to spacings according UL508. The appropriate spacings has to be determined in the end use application. The maximum Voltage rating each element could be max. 1000 V Ac. Therefore the spacing related to UL508 have to be 601-1000 V 14 mm through air and 25.4 mm over surface.
- ▶ The temperature rating of the connection cable shall be at least 105 °C to ensure proper connection.
- ▶ The required wire bending space and the spacings at the terminals after connection shall be determined in the end use application.

3 Product description

Overview

3 Product description

3.1 Overview

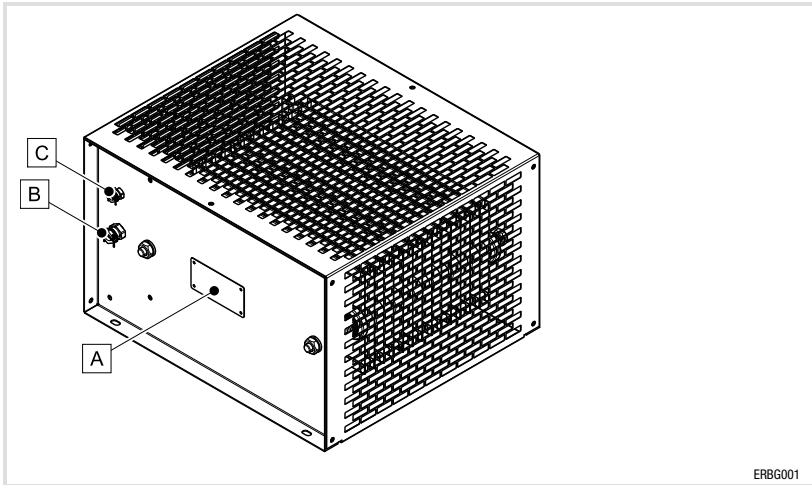

Scope of supply

Pos.	Description
	Brake resistor
	Mounting Instructions

Brake resistor elements

Pos.	Description
A	Nameplate
B	Cable gland for brake resistor cable
C	Cable gland for thermal contact cable

3.2 Identification



3.3**Application as directed**

Brake resistors

- ▶ must only be actuated under the operating conditions specified in these operating instructions.
- ▶ are components
 - for mounting in a machine.
 - for assembly with other components to a machine.

Commissioning of the brake resistor is prohibited until it has been determined that the machine into which the brake resistor is to be mounted complies with the regulations of the EC Machinery Directive.

- ▶ are electrical equipment for mounting in control cabinets or similar closed electrical operating areas.
- ▶ comply with the protective requirements of the "Low voltage" EC Directive.
- ▶ are not machines as defined by the Machines EC Directive.
- ▶ are not household appliances, but are only designed as components for subsequent commercial use.

Drive systems with brake resistors

- ▶ The responsibility for compliance with the EC Directives in the machine application is that of the re-user.

Any other use shall be deemed inappropriate!

3.4 Dimensioning conditions

If brake resistors are used, observe the following:

- ▶ Mean value of regenerative power < permanent power P_d of the brake resistor.
- ▶ Regenerative power during braking time < heat quantity Q_B of the brake resistor.
- ▶ Braking time < 10 % of cycle time (braking time + dead time).
- ▶ Always connect the thermal contact and integrate it in a way into the system monitoring that the mains supply will be switched off when the standard device is overheated.

At all times, the following must apply: In the time interval $t_{cyc, RB}$ (brake resistor cycle) the cumulative braking times t_{brk} must always be \leq of the maximum total braking time $t_{brk, max}$.

Calculation

Brake resistor cycle $t_{cyc, RB}$:

$$t_{cyc, RB} = \frac{Q_B}{P_d} \text{ with}$$

Q_B Heat quantity in Ws
 P_d Permanent power in W

Max. total braking time $t_{brk, max}$ within the time interval $t_{cyc, RB}$:

$$t_{brk, max} = \frac{Q_B \cdot R_B}{U_{max}^2} \text{ with}$$

Q_B Heat quantity in Ws
 R_B Resistance in Ω
 U_{max} Max. operating voltage in V

Examples of the evaluation of the condition

The brake resistor cycle $t_{\text{cyc, RB}} = 150 \text{ s}$ and the max. total braking time $t_{\text{brk, max}} = 10 \text{ s}$ are given. The braking times t_{brk} and the process cycle $t_{\text{cyc, Prc}}$ are exemplary.

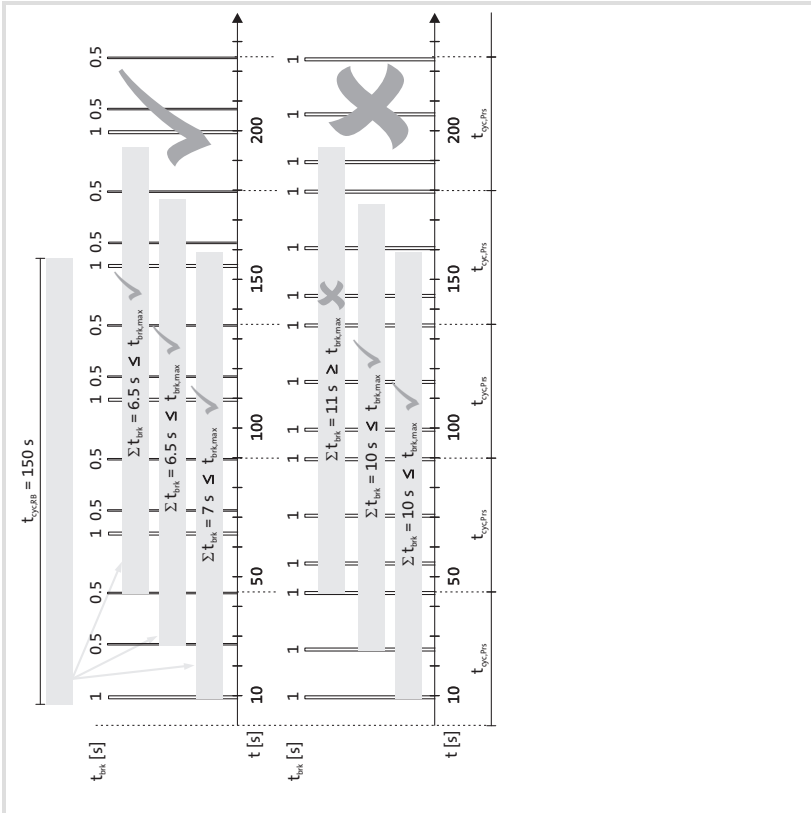

In the above example, the dimensioning condition is observed at all times. In the example below, the dimensioning condition is once not observed, which means that the brake resistor selected is not suitable for the process specified. Use a brake resistor with a greater power (shorter brake resistor cycle $t_{\text{cyc, RB}}$).

4 Technical data

4.1 General data and operating conditions

Conformity and approval

Conformity

CE	2006/95/EC	Low-Voltage Directive	
EAC	TP TC 020/2011 (TR CU 020/2011)	Electromagnetic compatibility of technical means	Eurasian Conformity TR CU: Technical Regulation of Customs Union
EAC	TP TC 004/2011 (TR CU 004/2011)	On safety of low voltage equipment	Eurasian Conformity TR CU: Technical Regulation of Customs Union

Approval

UR	UL508	Industrial Control Equipment, Underwriter Laboratories (File-No. E221095) for USA and Canada	
----	-------	--	--

Protection of persons and equipment

Enclosure	EN 60529	IP20	
	NEMA 250	Protection against contact to type 1	
Thermal contact			
Design		NC contact, 100 °C	
Switching capacity		250 V AC / 2.5 A 110 V AC / 1.6 A	

Environmental conditions

Climate

Storage	IEC/EN 60721-3-1	1K3 (-25 ... +60 °C)
Transport	IEC/EN 60721-3-2	2K3 (-25 ... +70 °C)
Operation	IEC/EN 60721-3-3	3K3 (-10 ... +55 °C) Current derating from +45 ... +55 °C: 1 %/°C
Site altitude		0 ... 4000 m amsl 1000 ... 4000 m amsl: Current derating 5 %/1000 m
Vibration resistance (9.81 m/s ² = 1 g)	EN 50178, IEC 61800-5-1, Germanischer Lloyd, general conditions	Acceleration resistant up to 0.7 g

Mounting conditions		
Mounting location		<ul style="list-style-type: none"> • The mounting location must comply with the device features mentioned in the chapter "General data". • Flammable materials or substances may not be placed in the vicinity of the brake resistor. • The heat generated by the brake resistor must be dissipated freely.
Mounting position		
Standard		Horizontally standing
Variant		Vertically suspended with connections at the bottom.
Free spaces		
Standard		Top > 200 mm To the sides > 100 mm
Variant		Top > 200 mm To the sides > 100 mm Bottom > 300 mm

4.2 Rated data

Electrical data				
	R_B	P_d	Q_B	U_{max}
	[Ω]	[W]	[kW/s]	[V _{DC}]
ERBG023D05K6	2.3	5600	840	1000
ERBG028D04K1	2.8	4100	615	
ERBG035D03K3	3.5	3300	495	
ERBG043D03K0	4.3	3000	450	
ERBG005R02K6	5.0	2600	390	
ERBG075D01K9	7.5	1900	285	
ERBG012R01K9	12.0			
ERBG012R05K2		5200	780	
ERBG015R03K3	15.0	3300	495	
ERBG015R06K2		6200	930	
ERBG015R10K0		10000	1500	
ERBG018R04K3		18.0	4300	

R_B Resistance
 P_d Permanent power
 Q_B Heat quantity
 U_{max} Max. operating voltage

Temperatures			
	T_{nom}	T_{TK}	T_{max}
		[°C]	
Inside	390	530	690
At the housing	200	240	300
On the clearance edge *)	120	160	200

T_{nom} Maximum temperature for rated data
 T_{TK} Temperature at which the thermal contact is activated
 T_{max} Maximum temperature in the case of improper use
 *) Measured for air as the ambient medium (small coefficient of thermal conductivity); if materials which heat up are located at the clearance edge (greater coefficient of thermal conductivity), the temperature continues to rise.

4 Technical data

Mechanical data

4.3 Mechanical data

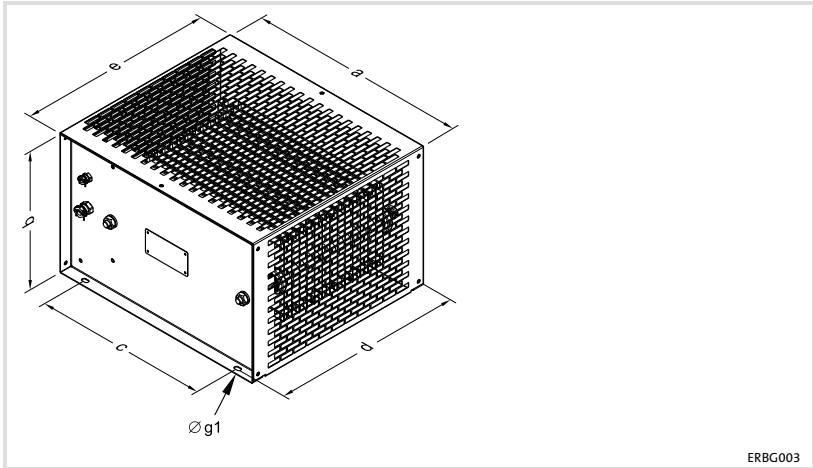

	a	b	c	d	e	g1	
	[mm]						[kg]
ERBG023D05K6	486	302	380	400	426	6.3	15.9
ERBG028D04K1							12.8
ERBG035D03K3							12.6
ERBG043D03K0				300	326		11.8
ERBG005R02K6							11.0
ERBG075D01K9				210	236		9.5
ERBG012R01K9							
ERBG012R05K2				400	426		15.1
ERBG015R03K3				300	326		12.6
ERBG015R06K2				500	526		17.0
ERBG015R10K0				710	736		22.0
ERBG018R04K3				400	426		13.5

Free spaces for standard mounting

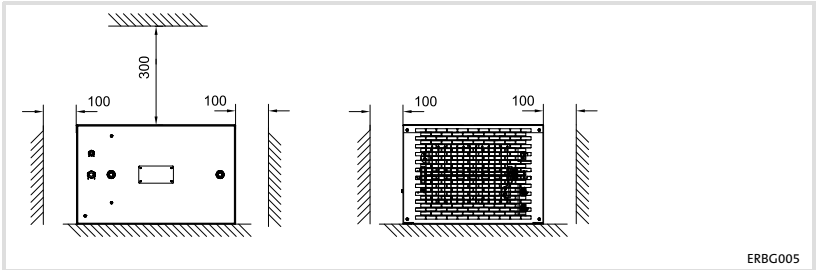

All dimensions in millimetres.

Free spaces for mounting variant

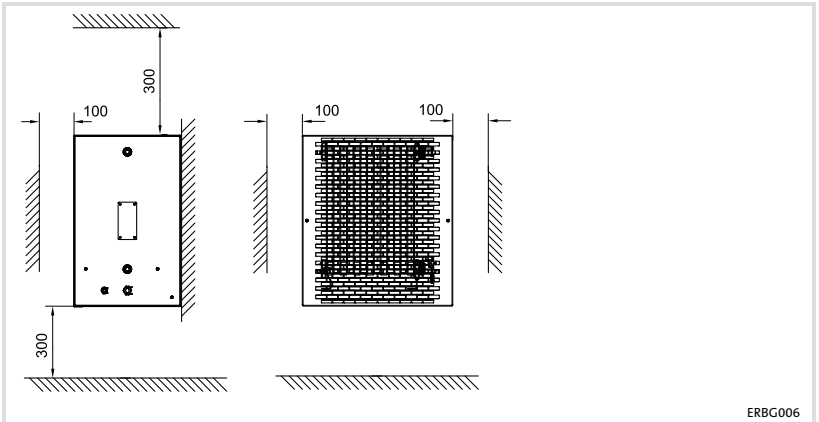

All dimensions in millimetres.

5 Mechanical installation

Mounting steps

5 Mechanical installation

5.1 Mounting steps

How to mount the brake resistor:

1. Select a suitable mounting location.
 - The mounting location must always ensure the operating conditions mentioned in the technical data; if required, additional measures must be taken.
 - Ensure unimpeded air circulation for heat dissipation.
2. Screw down the brake resistor at the mounting location.
 - The mounting location and the mounting material must ensure the permanent mechanical connection.

6 Electrical installation

6.1 Important notes



Stop!

Possible overheating of the brake resistor during operation

Inadequate heat dissipation during operation can cause the brake resistor to overheat.

Possible consequences:

- ▶ The brake resistor is destroyed.
- ▶ The drive is not braked but coasts to a standstill.

Protective measures:

- ▶ Always connect the thermal contact of the brake resistor.
- ▶ Integrate the thermal contact into the overall equipment monitoring apparatus in such a way that the supply of power to the standard device is switched off if the brake resistor overheats (e.g. switch-off by means of mains contactor control).

6.2 Connection data

Connection	Cable gland	Connection type	Connection size	Starting torque
RB1, RB2 (brake resistor) PE (PE conductor)	M25 / M40 ¹⁾	Stud terminal	M6	4 Nm 35.4 lb-in
T1, T2 (thermal contact)	M16	Tunnel terminal	0.75 ... 1.5 mm ² 18 ... 16 AWG	0.32 Nm 2.85 lb-in

¹⁾ ERBG023D05K6, ERBG028D04K1



Tip!

The brake resistor has two PE connections, one inside, the other outside the housing.

- ▶ If you use a brake resistor cable with PE conductor, lead this through the cable gland and place the PE conductor inside.
- ▶ If you use a separate PE cable, connect it outside.

6 Electrical installation

Connection plan

6.3 Connection plan

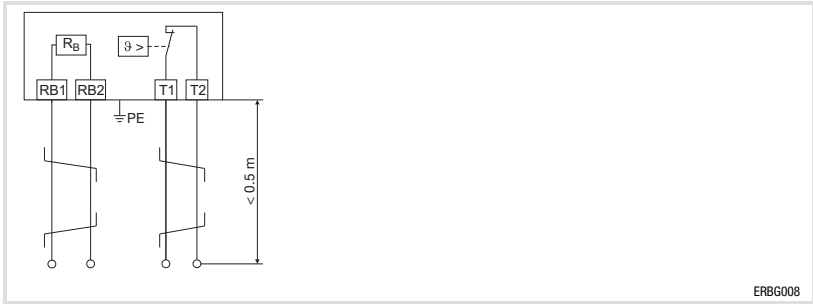

Version 1 (short cables)

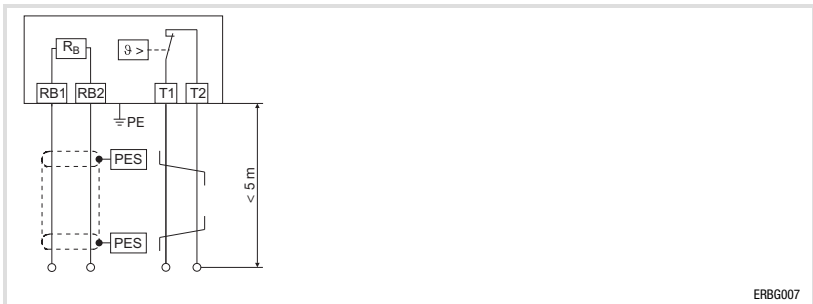

 Twisted cables

Version 2 (long cables)





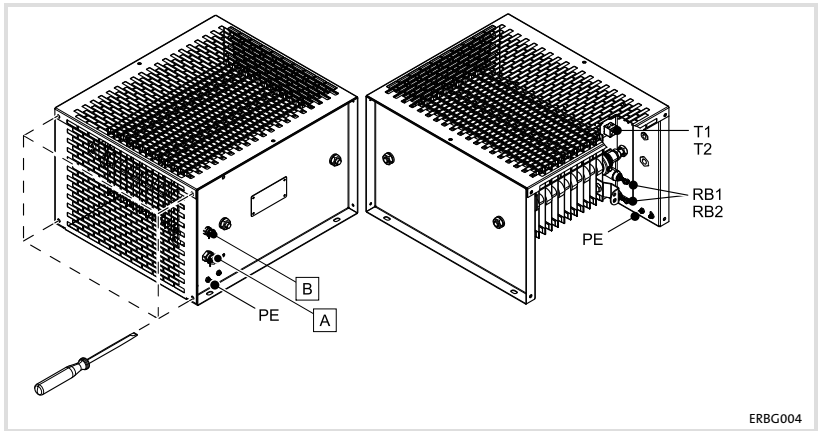

 HF-shield termination by extensive PE connection
 Twisted cables

6.4 Mounting steps



How to connect the brake resistor:

1. Disconnect the basic device from the mains and check that no voltage is applied to the power terminals.
2. Remove the terminal cover.
3. Connect the brake resistor cable:
 - Use a twisted cable for cables up to 0.5 m (connection plan variant 1).
 - Use a shielded cable for cables up to 5 m (connection plan variant 2).
 - Pass the cable through the cable gland .
 - Connect the cores to connections RB1, RB2 and PE of the brake resistor observing the tightening torque. PE connection to EN 61800-5-1.
 - Tighten the cable gland .
 - For shielded cables: Securely connect the shield to the cable gland with a surface as large as possible.
 - Connect cores and shield to the basic device observing the documentation for the basic device.
4. Connect the thermal contact cables:
 - Use a twisted cable.
 - Pass the cable through the cable gland .
 - Connect the cores to connections T1 and T2 of the brake resistor observing the tightening torque.
 - Tighten the cable gland .
 - When integrating the thermal contact into the system monitoring ensure that the mains supply will be switched off when the brake resistor is overheated.
5. Mount the terminal cover.



Note!

If the brake resistor is switched on for the first time or has not been used for a longer period of time, a smell may develop together with a low smoke emission. This is harmless.

7 Maintenance

7.1 Maintenance intervals

The brake resistor is maintenance-free. Nevertheless, a visual inspection must be executed in short and regular intervals considering the ambient conditions.

Ensure that:

- ▶ the environment of the brake resistor still corresponds to the operating conditions included in the technical data.
- ▶ no dust or dirt impedes the heat dissipation of the brake resistor.
- ▶ the mechanical and electrical connections are correct.

7.2 Maintenance operations

Cleaning the brake resistor

1. Disconnect the standard device from the mains and wait at least three minutes.
2. Check temperature of the brake resistor and allow it to cool, if required.
3. Check the brake resistor for safe isolation from supply.
4. Clean brake resistor without using cleaning agents.



1	Présentation du document	56
1.1	Validité	56
1.2	Public visé	56
1.3	Historique du document	56
1.4	Conventions utilisées	57
1.5	Consignes utilisées	58
2	Consignes de sécurité	60
2.1	Consignes générales	60
2.2	Dangers résiduels	61
3	Description du produit	64
3.1	Présentation générale	64
3.2	Identification	65
3.3	Utilisation conforme à la fonction	66
3.4	Conditions de référence	67
4	Spécifications techniques	69
4.1	Caractéristiques générales et conditions d'utilisation	69
4.2	Caractéristiques assignées	71
4.3	Caractéristiques mécaniques	72
5	Installation mécanique	74
5.1	Opérations de montage	74
6	Installation électrique	75
6.1	Remarques importantes	75
6.2	Données de raccordement	76
6.3	Schéma de câblage	77
6.4	Opérations de montage	78
7	Maintenance	80
7.1	Intervalles de maintenance	80
7.2	Opérations de maintenance	80

1 Présentation du document

Validité

1 Présentation du document

1.1 Validité

Le présent document s'applique aux produits suivants :

- ▶ aux résistances de freinage ERBGxxxxxxxx.

1.2 Public visé

Cette documentation s'adresse à un personnel qualifié et habilité conformément à la norme CEI 60364.

On entend par "personnel qualifié et habilité" des personnes compétentes en matière d'installation, de montage, de mise en service et de fonctionnement du produit et possédant les qualifications correspondant à leurs activités.



Conseil !







Toutes les informations relatives aux produits Lenze peuvent être téléchargées sur notre site à l'adresse suivante :

www.Lenze.com

1.3 Historique du document

Numéro de matériel	Version			Description
13474656	8.0	10/2014	TD29	Consignes UL en français pour le Canada Conformité EAC Corrections générales
13314940	7.0	01/2011	TD29	Édition revue

1.4 Conventions utilisées

Type d'information	Aperçu	Exemples/remarques
Représentation des chiffres		
Séparateur décimal	Point	Le point décimal est généralement utilisé. Exemple : 1234.56
Consignes préventives		
Consignes préventives UL		En anglais et en français
Consignes préventives UR		
Mise en évidence de textes spéciaux		
Nom de programme	» «	Logiciel pour PC Exemple : »Engineer«, »Global Drive Control« (GDC)
Pictogrammes		
Renvoi à la page		Renvoi à une autre page contenant des informations supplémentaires. Par exemple :  16 = voir page 16
Renvoi à une documentation		Renvoi à une autre documentation contenant des informations supplémentaires. Par exemple :  EDKxxx = voir la documentation EDKxxx

1 Présentation du document





Consignes utilisées

1.5 Consignes utilisées



Pour indiquer des risques et des informations importantes, la présente documentation utilise les mots et pictogrammes suivants :

Consignes de sécurité



Présentation des consignes de sécurité

	Danger ! (Le pictogramme indique le type de risque.) Explication (L'explication décrit le risque et les moyens de l'éviter.)
Pictogramme et mot associé	Explication
	Danger ! Situation dangereuse pour les personnes en raison d'une tension électrique élevée Indication d'un danger imminent qui peut avoir pour conséquences des blessures mortelles ou très graves en cas de non-respect des consignes de sécurité correspondantes
	Danger ! Situation dangereuse pour les personnes en raison d'un danger d'ordre général Indication d'un danger imminent qui peut avoir pour conséquences des blessures mortelles ou très graves en cas de non-respect des consignes de sécurité correspondantes
	Stop ! Risques de dégâts matériels Indication d'un risque potentiel qui peut avoir pour conséquences des dégâts matériels en cas de non-respect des consignes de sécurité correspondantes

Consignes d'utilisation

Pictogramme et mot associé	Explication
	Remarque importante ! Remarque importante pour assurer un fonctionnement correct
	Conseil ! Conseil utile pour faciliter la mise en œuvre
	Renvoi à une autre documentation

Consignes de sécurité et d'utilisation spécifiques selon UL et UR

Pictogramme et mot associé	Explication
 Avertissements !	Consigne de sécurité ou d'utilisation pour le fonctionnement d'un appareil homologué UL dans des installations homologuées UL Le système d'entraînement risque de ne pas être utilisé selon les directives UL si des mesures correspondantes ne sont pas prévues.
 Avertissements !	Consigne de sécurité ou d'utilisation pour le fonctionnement d'un appareil homologué UR dans des installations homologuées UL Le système d'entraînement risque de ne pas être utilisé selon les directives UL si des mesures correspondantes ne sont pas prévues.

2 Consignes de sécurité

2.1 Consignes générales



Danger !

Le non-respect des consignes fondamentales de sécurité suivantes peut entraîner des blessures et des dommages matériels graves.

- ▶ Les composants d'entraînement et d'automatisation Lenze ...
 - ... doivent exclusivement être utilisés conformément à leur fonction.
 - ... ne doivent jamais être mis en service si des dommages sont décelés.
 - ... ne doivent jamais être modifiés d'un point de vue technique.
 - ... ne doivent jamais être mis en service s'ils ne sont pas montés intégralement.
 - ... ne doivent jamais être mis en service sans le capot obligatoire.
 - ... peuvent - selon l'indice de protection - contenir des pièces sous tension, en mouvement ou en rotation. Les surfaces peuvent être brûlantes.
- ▶ Respecter les consignes et les indications contenues dans la documentation concernée.

Il s'agit de la condition préalable pour garantir un fonctionnement sûr et fiable et pour obtenir les caractéristiques du produit indiquées.

Les procédures à suivre et les plans de raccordement fournis constituent des recommandations dont l'adéquation avec l'application concernée doit être vérifiée. Lenze n'assumera aucune responsabilité pour les dommages liés à un problème d'adéquation des procédures et plans de raccordements indiqués.
- ▶ Les travaux réalisés avec et au niveau des composants d'entraînement et d'automatisation Lenze ne doivent être exécutés que par un personnel qualifié et habilité.

Selon les normes CEI 60364 ou CENELEC HD 384, ces personnes doivent ...

 - ... connaître parfaitement l'installation, le montage, la mise en service et le fonctionnement du produit.
 - ... posséder les qualifications appropriées pour l'exercice de leur activité.
 - ... connaître toutes les prescriptions pour la prévention d'accidents, directives et lois applicables sur le lieu d'utilisation et être en mesure de les appliquer.

2.2 Dangers résiduels



Danger !

Tension électrique dangereuse

Les raccords de la résistance de freinage sont sous tension pendant le fonctionnement de l'appareil de base et **jusqu'à 3 minutes après la coupure réseau.**

Risques encourus

- ▶ Mort ou blessures très graves en cas de contact accidentel avec les bornes de raccordement.

Mesures de protection

- ▶ Couper l'appareil de base du réseau avant toute manipulation de la résistance de freinage ;
- ▶ Vérifier si les bornes de puissance sont hors tension ;
- ▶ Sélectionner l'emplacement de montage de façon à ce que les conditions d'utilisation (voir Spécifications techniques) soient garanties à tout instant.



Danger !

Surface brûlante pendant le fonctionnement

Pendant le fonctionnement, la surface de la résistance de freinage peut atteindre une température extrêmement élevée (pour les températures, voir Spécifications techniques).

Risques encourus :

- ▶ Brûlures très graves en cas de contact accidentel
- ▶ Incendie ou feu couvant si des objets ou des matériaux combustibles se trouvent (ou risquent de se trouver) à proximité de la résistance de freinage

Mesures de protection :

- ▶ Avant toute manipulation, vérifier la température de surface de la résistance de freinage.
- ▶ Sélectionner l'emplacement de montage de façon à ce que les conditions d'utilisation (voir Spécifications techniques) soient garanties à tout instant.
- ▶ Prévoir une protection contre l'incendie pour l'emplacement de montage, ainsi qu'un système de protection contre les contacts accidentels.

**Stop !****Risque de surchauffe de la résistance de freinage pendant le fonctionnement**

Une dissipation calorifique insuffisante pendant le fonctionnement risque de provoquer une surchauffe de la résistance de freinage.

Risques encourus :

- ▶ Dommages irréversibles de la résistance de freinage
- ▶ L'entraînement n'est pas freiné mais part en roue libre.

Mesures de protection :

- ▶ Connecter impérativement le contact thermique de la résistance de freinage.
- ▶ Intégrer le contact thermique dans la surveillance de l'installation de façon à ce qu'en cas de surchauffe de la résistance de freinage, l'alimentation de l'appareil de base soit coupée (exemple : coupure de la commande de l'interrupteur réseau).



Avertissements !

Conditions d'acceptabilité :

- ▶ Les produits concernés par ce rapport sont destinés exclusivement à être utilisés avec des convertisseurs de puissance ou des équipements assimilés (power conversion equipment).
- ▶ Ils ont été testés en vue d'un montage en position horizontale. Si d'autres positions de montage s'avèrent nécessaires dans les conditions d'application finales, il convient de procéder à un test de température pour garantir l'élévation de température maximale.
- ▶ Ces équipements sont destinés exclusivement à être câblés à l'usine. Le connecteur de câble à cosse doit être monté directement à la surface du jeu de barres de cuivre pour assurer un raccordement conforme.
- ▶ Les tests de température ont été menés pour un fonctionnement permanent conformément aux indications fournies dans le tableau des caractéristiques nominales avec un fond fermé. La capacité de chauffage et l'élévation maximale de température pour des courants nominaux supérieurs et des cycles de fonctionnement plus courts doivent être déterminées dans les conditions d'application finales.
- ▶ L'équipement a été évalué au regard des espacements prescrits par la norme UL508. Les espacements appropriés doivent être déterminés dans les conditions d'application finales. La tension nominale maximale de chaque élément peut atteindre 1000 VCA. Par conséquent, conformément à la norme UL508, les espacements mesurés dans l'air et sur la surface doivent être de 14 mm (601-1000 V) et de 25,4 mm, respectivement.
- ▶ La température assignée du câble doit être d'au moins 105 °C pour assurer un raccordement conforme.
- ▶ L'espace de courbure des câbles requis et les espacements entre les bornes après le raccordement doivent être déterminés dans les conditions d'application finales.

3 Description du produit

Présentation générale

3 Description du produit

3.1 Présentation générale

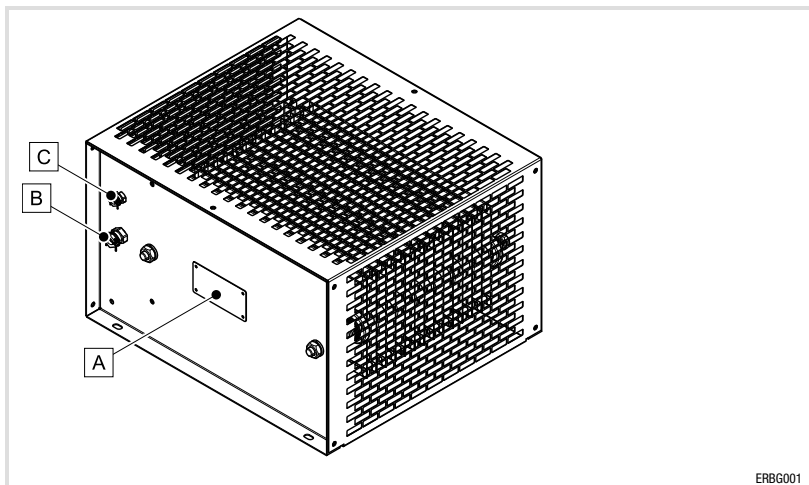

Équipement livré

Pos.	Description
	Résistance de freinage
	Instructions de montage

Éléments de la résistance de freinage

Pos.	Description
A	Plaque signalétique
B	Presse-étoupe du câble de la résistance de freinage
C	Presse-étoupe du câble du contact thermique

3.2 Identification



3.3 Utilisation conforme à la fonction

Les résistances de freinage

- ▶ ne doivent être utilisées qu'aux fins décrites dans les présentes instructions de montage.
 - ▶ sont des composants destinés
 - à être intégrés dans une machine.
 - à être assemblés avec d'autres composants pour former une machine.
- Avant de mettre en service la résistance de freinage, s'assurer que la machine destinée à l'accueillir est conforme aux exigences de la directives CE sur les machines.
- ▶ sont des composants électriques destinés à être montés dans une armoire électrique ou dans un local de service fermé similaire.
 - ▶ répondent aux exigences de sécurité prescrites par la directive CE Basse tension.
 - ▶ ne sont pas des machines au sens de la directive CE sur les machines.
 - ▶ ne sont pas des équipements ménagers, mais des composant destinés exclusivement à un usage industriel.

Systèmes d'entraînement avec résistances de freinage

- ▶ La responsabilité du respect des directives CE pendant le fonctionnement de la machine incombe à l'exploitant.

Toute autre utilisation est contre-indiquée !

3.4 Conditions de référence

En cas d'utilisation de résistances de freinage, tenir compte des points suivants :

- ▶ Puissance génératrice moyenne < puissance permanente P_d de la résistance de freinage
- ▶ Puissance génératrice pendant le temps de freinage < puissance calorifique Q_B du résistance de freinage.
- ▶ Temps de freinage < 10 % du temps de cycle (temps de freinage + temps de repos)
- ▶ Raccorder impérativement le contact thermique et l'intégrer dans la surveillance de l'installation de façon à ce qu'en cas de surchauffe de la résistance de freinage, l'alimentation réseau de l'appareil de base soit coupée.

La règle suivante s'applique à tout instant : durant $t_{cyc,RB}$ (cycle de la résistance de freinafe), les temps de freinage t_{brk} cumulés doivent systématiquement être \leq au temps de freinage maximal $t_{brk,max}$.

Calcul

Cycle de la résistance de freinage $t_{cyc,RB}$:

$$t_{cyc,RB} = \frac{Q_B}{P_d} \text{ avec}$$

Q_B Puissance calorifique en Ws
 P_d Puissance permanente en W

Temps de freinage max. $t_{brk,max}$ durant l'intervalle de temps $t_{cyc,RB}$:

$$t_{brk,max} = \frac{Q_B \cdot R_B}{U_{max}^2} \text{ avec}$$

Q_B Puissance calorifique en Ws
 R_B Résistance en Ω
 U_{max} Tension de fonctionnement max. en V

Exemples d'évaluation de la condition de référence

Données de base : cycle de la résistance de freinage $t_{cyc, RB} = 150$ s et temps de freinage max. $t_{brk, max} = 10$ s. Les temps de freinage t_{brk} et le cycle du process $t_{cyc, Prc}$ sont fournis à titre indicatifs.

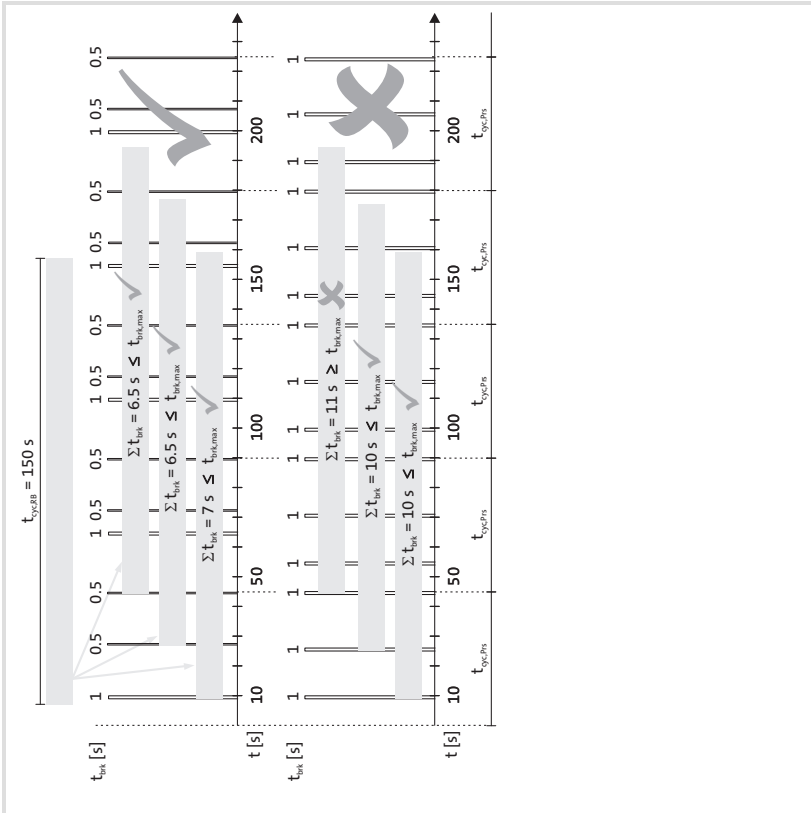

Dans le premier exemple, la condition de référence est constamment respectée. Dans le second, il y a une exception : la résistance de freinage sélectionnée n'est pas adaptée au process réglé. Sélectionner une résistance de freinage plus puissante (cycle $t_{cyc, RB}$ plus court).

4 Spécifications techniques

4.1 Caractéristiques générales et conditions d'utilisation

Conformité et homologation

Conformité

CE	2006/95/CE	Directive Basse Tension	
EAC	TP TC 020/2011 (RT UD 020/2011)	Compatibilité électromagnétique des équipements	Conformité eurasienne RT UD : Règlement technique de l'Union Douanière
EAC	TP TC 004/2011 (RT UD 004/2011)	Sécurité des équipements à basse tension	Conformité eurasienne RT UD : Règlement technique de l'Union Douanière

Homologation

UR	UL508	Industrial Control Equipment, Underwriter Laboratories (File-No. E221095) for USA and Canada	
----	-------	--	--

Protection des personnes et protection de l'appareil

Indice de protection	EN 60529	IP20	
	NEMA 250	Protection contre les contacts accidentels de type 1	
Contact thermique			
Version	Contact à ouverture, 100 °C		
Puissance de commutation	250 V CA / 2.5 A 110 V CA / 1.6 A		

Conditions climatiques

Climatisation

Stockage	CEI/EN 60721-3-1	1K3 (-25 ... +60 °C)
Transport	CEI/EN 60721-3-2	2K3 (-25 ... +70 °C)
Fonctionnement	CEI/EN 60721-3-3	3K3 (-10 ... +55 °C) Réduction de courant entre +45 ... +55 °C : 1 %/°C
Altitude d'implantation		0 ... 4000 m au-dessus du niveau de la mer 1000 ... 4000 m au-dessus du niveau de la mer : réduction de courant de 5 %/1000 m
Résistance aux chocs (9.81 m/s ² = 1 g)	EN 50178, CEI 61800-5-1, Germanischer Lloyd, conditions générales	Résistant à l'accélération jusqu'à 0.7 g

Conditions de montage		
Emplacement de montage		<ul style="list-style-type: none"> • L'emplacement de montage doit correspondre aux caractéristiques indiquées au chapitre Caractéristiques générales. • Des objets ou des matériaux combustibles ne doivent pas se trouver à proximité de la résistance de freinage. • Assurer une ventilation suffisante pour évacuer la chaleur dissipée par la résistance de freinage.
Position de montage		
Standard		Position horizontale
Variante		Position verticale avec câbles de raccordement vers le bas
Espacements de montage		
Standard		Au-dessus de l'appareil > 200 mm sur les côtés de l'appareil > 100 mm
Variante		Au-dessus de l'appareil > 200 mm sur les côtés de l'appareil > 100 mm en dessous de l'appareil > 300 mm

4.2 Caractéristiques assignées

Caractéristiques électriques				
	R_B	P_d	Q_B	U_{max}
	[Ω]	[W]	[kWs]	[V _{DC}]
ERBG023D05K6	2.3	5600	840	1000
ERBG028D04K1	2.8	4100	615	
ERBG035D03K3	3.5	3300	495	
ERBG043D03K0	4.3	3000	450	
ERBG005R02K6	5.0	2600	390	
ERBG075D01K9	7.5	1900	285	
ERBG012R01K9	12.0			
ERBG012R05K2		5200	780	
ERBG015R03K3	15.0	3300	495	
ERBG015R06K2		6200	930	
ERBG015R10K0		10000	1500	
ERBG018R04K3		18.0	4300	

R_B Résistance
 P_d Puissance permanente
 Q_B Puissance calorifique
 U_{max} Tension de fonctionnement maxi

Températures			
	T_{nom}	T_{TK}	T_{max}
		[°C]	
A l'intérieur	390	530	690
Sur le coffret	200	240	300
au niveau de la zone de dégagement *)	120	160	200

T_{nom} Températures maximales pour les caractéristiques assignées
 T_{TK} Seuil de déclenchement du contact thermique
 T_{max} Température maximale en cas d'utilisation contre-indiqué(e)
 *) Mesurée avec air ambiant (faible conductivité thermique) ; la température augmente encore quand la zone de dégagement contient des matériaux / matières qui à plus forte conductivité thermique.

4 Spécifications techniques

Caractéristiques mécaniques

4.3 Caractéristiques mécaniques

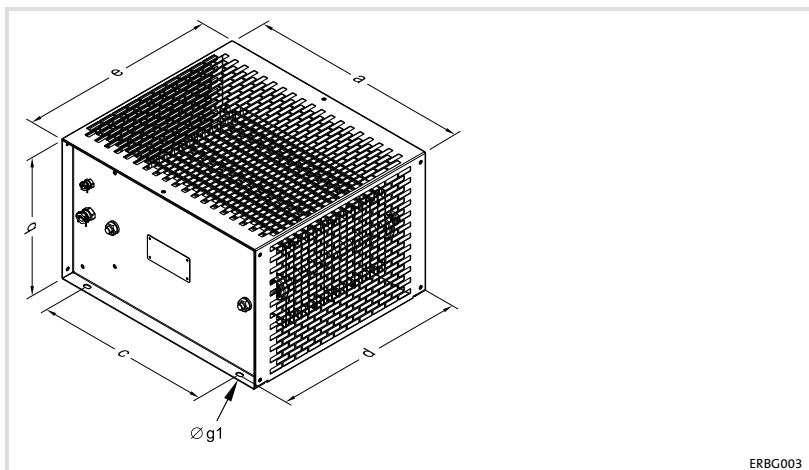

	a	b	c	d	e	g1	 [kg]
	[mm]						
ERBG023D05K6	486	302	380	400	426	6.3	15.9
ERBG028D04K1							12.8
ERBG035D03K3							12.6
ERBG043D03K0				300	326		11.8
ERBG005R02K6							11.0
ERBG075D01K9				210	236		9.5
ERBG012R01K9							
ERBG012R05K2				400	426		15.1
ERBG015R03K3				300	326		12.6
ERBG015R06K2				500	526		17.0
ERBG015R10K0				710	736		22.0
ERBG018R04K3				400	426		13.5

Espacements à respecter pour le montage standard

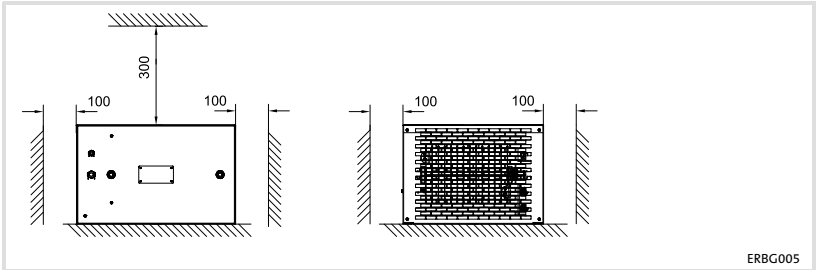

Cotes en [mm]

Espacements à respecter pour la variante de montage

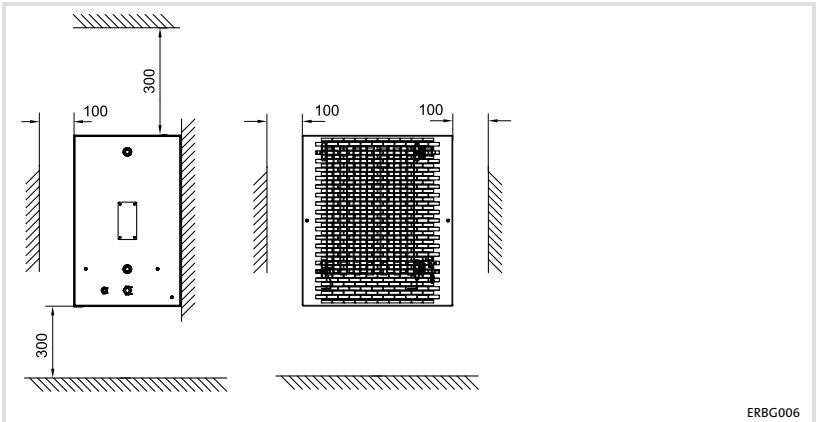

Cotes en [mm]

5 Installation mécanique

Opérations de montage

5 Installation mécanique

5.1 Opérations de montage

Ordre des opérations de montage de la résistance de freinage :

1. Sélectionner l'emplacement de montage adéquat.
 - Sélectionner l'emplacement de montage de façon à ce que les conditions d'utilisation (voir Spécifications techniques) soient garanties à tout instant ; le cas échéant, prévoir des mesures supplémentaires.
 - Prévoir une ventilation suffisante pour assurer un refroidissement rapide.
2. Visser la résistance de freinage à l'emplacement de montage.
 - L'emplacement de montage et le matériel de montage doivent garantir une liaison mécanique permanente.

6 Installation électrique

6.1 Remarques importantes



Stop !

Risque de surchauffe de la résistance de freinage pendant le fonctionnement

Une dissipation calorifique insuffisante pendant le fonctionnement risque de provoquer une surchauffe de la résistance de freinage.

Risques encourus :

- ▶ Dommages irréversibles de la résistance de freinage
- ▶ L'entraînement n'est pas freiné mais part en roue libre.

Mesures de protection :

- ▶ Connecter impérativement le contact thermique de la résistance de freinage.
- ▶ Intégrer le contact thermique dans la surveillance de l'installation de façon à ce qu'en cas de surchauffe de la résistance de freinage, l'alimentation de l'appareil de base soit coupée (exemple : coupure de la commande de l'interrupteur réseau).

6.2 Données de raccordement

Raccordement	Presse-étoupe à vis	Type de raccordement	Cotes de raccordement	Couple de serrage
RB1, RB2 (résistance de freinage)	M25 / M40 ¹⁾	Borne fileté	M6	4 Nm 35.4 lb-in
PE (conducteur de protection)				
T1, T2 (contact thermique)	M16	Barrette de connexion	0.75 ... 1.5 mm ² 18 ... 16 AWG	0.32 Nm 2.85 lb-in

1) ERBG023D05K6, ERBG028D04K1



Conseil !

La résistance de freinage est équipée de deux raccordements PE dont l'un se trouve à l'intérieur du coffret et l'autre à l'extérieur.

- ▶ En utilisant un câble de résistance de freinage avec conducteur PE, le faire passer par le presse-étoupe et raccorder le conducteur PE à l'intérieur du coffret.
- ▶ En utilisant un câble PE séparé, raccorder celui-ci à l'extérieur.

6.3 Schéma de câblage

Variante 1 (câbles courts)



Câbles torsadés

Variante 2 (câbles longs)



PES

Connexion HF (collier de blindage) via connexion avec PE par surface importante



Câbles torsadés



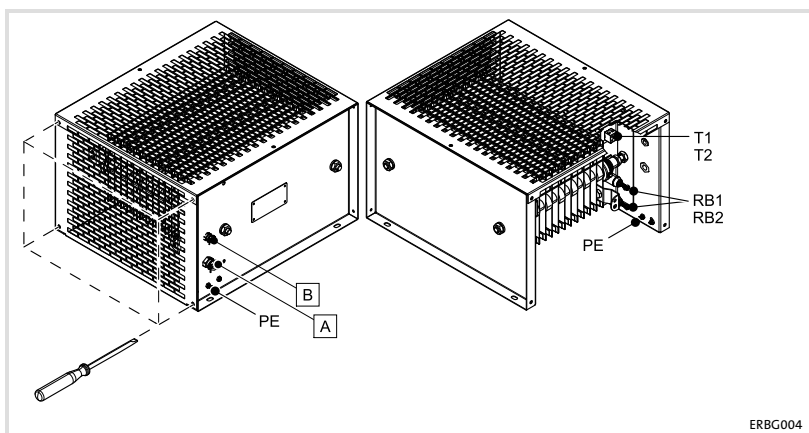

6 Installation électrique

Opérations de montage

6.4 Opérations de montage



Ordre des opérations de raccordement de la résistance de freinage

1. Couper l'appareil de base du réseau et vérifier si toutes les bornes de puissance sont hors tension.
2. Démonter le cache-bornier.
3. Connexion du câble de la résistance de freinage
 - Pour les câbles d'une longueur jusqu'à 0.5 m, utiliser des câbles torsadés (voir schéma de câblage, variante 1).
 - Pour les câbles d'une longueur jusqu'à 5 m, utiliser des câbles blindés (voir schéma de câblage, variante 2).
 - Faire passer le câble par le presse-étoupe à vis .
 - Connecter les fils sur les raccords RB1, RB2 et PE de la résistance de freinage. Tenir compte du couple de serrage. Prévoir impérativement un raccordement PE selon EN 61800-5-1.
 - Serrer à fond le presse-étoupe à vis .
 - Lorsqu'un câble blindé est utilisé, relier le blindage à fond et par une surface importante avec le presse-étoupe.
 - Connecter les fils et le blindage sur l'appareil de base. Tenir compte de la documentation de l'appareil de base.
4. Connexion des câbles du contact thermique
 - Utiliser un câble torsadé.
 - Faire passer le câble par le presse-étoupe à vis .
 - Connecter les fils aux raccords T1 et T2 de la résistance de freinage. Tenir compte du couple de serrage.
 - Serrer à fond le presse-étoupe à vis .
 - Intégrer le contact thermique dans la surveillance de l'installation de façon à ce qu'en cas de surchauffe de la résistance de freinage, l'alimentation réseau soit coupée.
5. Monter le cache-bornier.

**Remarque importante !**

Après la première mise sous tension et, éventuellement, en cas de non-utilisation prolongée, vous constaterez peut-être un dégagement d'odeur associé à un faible dégagement de fumée émanant de la résistance de freinage. Ceci est sans inconvénient.

7 Maintenance

7.1 Intervalles de maintenance

La résistance ne nécessite aucun entretien. Cependant, il convient de procéder à des contrôles visuels réguliers. Selon les conditions ambiantes, prévoir des intervalles de contrôle suffisamment courts.

Vérifier

- ▶ si les conditions ambiantes de la résistance de freinage correspondent toujours à celles indiquées au chapitre Spécifications techniques ;
- ▶ si des poussières ou dépôts éventuels risquent d'entraver la dissipation thermique de la résistance de freinage ;
- ▶ si les liaisons mécaniques et électriques sont correctes.

7.2 Opérations de maintenance

Nettoyage de la résistance de freinage

1. Couper l'appareil de base du réseau et attendre 3 minutes au minimum.
2. Vérifier la température de la résistance de freinage et laisser refroidir si nécessaire.
3. Vérifier si les raccords de la résistance de freinage sont hors tension.
4. Nettoyer la résistance de freinage (ne faire qu'un nettoyage à sec, sans agent détergent).

1	Acerca de esta documentación	82
1.1	Información sobre la validez	82
1.2	Grupo objetivo	82
1.3	Historia del documento	82
1.4	Convenciones utilizadas	83
1.5	Indicaciones utilizadas	84
2	Instrucciones de seguridad	86
2.1	Instrucciones de seguridad generales	86
2.2	Peligros residuales	87
3	Descripción del producto	90
3.1	Vista general	90
3.2	Identificación	91
3.3	Uso previsto	92
3.4	Condiciones del dimensionado	93
4	Datos técnicos	95
4.1	Datos generales y condiciones de uso	95
4.2	Datos nominales	97
4.3	Datos mecánicos	98
5	Instalación mecánica	100
5.1	Pasos para el montaje	100
6	Instalación eléctrica	101
6.1	Indicaciones importantes	101
6.2	Datos de conexión	102
6.3	Esquema de conexiones	103
6.4	Pasos para el montaje	104
7	Mantenimiento	106
7.1	Intervalos de mantenimiento	106
7.2	Trabajos de mantenimiento	106

1 Acerca de esta documentación

Información sobre la validez

1 Acerca de esta documentación

1.1 Información sobre la validez

Este manual es de aplicación para

- ▶ Resistencias de frenado ERBGxxxxxxxx

1.2 Grupo objetivo

Esta documentación va dirigida a personal experto y cualificado según IEC 60364.

Personal experto cualificado son aquellas personas que disponen de las cualificaciones adecuadas para realizar los trabajos necesarios para la instalación, montaje, puesta en marcha y operación del producto.



¡Sugerencia!







Encontrará información y consejos sobre los productos de Lenze en el área de descargas en

www.lenze.com

1.3 Historia del documento

Número de material	Versión			Descripción
13474656	8.0	10/2014	TD29	Instrucciones UL en francés para Canadá Conformidad EAC Correcciones generales
13314940	7.0	01/2011	TD29	Versión revisada

1.4 Convenciones utilizadas

Tipo de información	Marcación	Ejemplos/indicaciones
Escritura de números		
Separación de decimales	Punto	Por norma general se utiliza el punto para los decimales. Por ejemplo: 1234.56
Advertencias		
Advertencias UL		Se utilizan en Inglés y Francés.
Advertencias UR		
Resalte del texto		
Nombre del programa	» «	Software para PC Por ejemplo: »Engineer«, »Global Drive Control« (GDC)
Símbolos		
Referencia a páginas		Referencia a otra página con información adicional Por ejemplo:  16 = véase la página 16
Referencia a otra documentación		Referencia a otra documentación con información adicional Por ejemplo:  EDKxxx = véase la documentación EDKxxx

1.5

Indicaciones utilizadas

Para indicar peligros e información importante, se utilizan en esta documentación los siguientes términos indicativos y símbolos:

Instrucciones de seguridad

Estructura de las instrucciones de seguridad:

**¡Peligro!**

(indican el tipo y la gravedad del peligro)

Texto indicativo



(describe el peligro y da instrucciones para evitarlo)

Pictograma y término indicativo	Significado
¡Peligro!	Riesgo de daños personales por voltaje eléctrico Indica un peligro inminente que puede causar la muerte o lesiones graves si no se toman las medidas adecuadas.
¡Peligro!	Riesgo de daños personales por una fuente de riesgo general Indica un peligro inminente que puede causar la muerte o lesiones graves si no se toman las medidas adecuadas.
¡Alto!	Peligro de daños materiales Indica un posible riesgo que puede ocasionar daños materiales si no se toman las medidas adecuadas.

Instrucciones de uso

Pictograma y término indicativo	Significado
¡Aviso!	Nota importante para el funcionamiento sin fallos
¡Sugerencia!	Sugerencia útil para facilitar la operación
	Referencia a otra documentación

Instrucciones de seguridad y de uso especiales para UL y UR

Pictograma y término indicativo	Significado
 Warnings!	<p>Instrucción de seguridad o de uso para la utilización de un equipo con aprobación UL en instalaciones con aprobación UL.</p> <p>Posiblemente el sistema de accionamiento no funcionará según UL si no se toman las medidas adecuadas.</p>
 Warnings!	<p>Instrucción de seguridad o de uso para la utilización de un equipo con aprobación UR en instalaciones con aprobación UL.</p> <p>Posiblemente el sistema de accionamiento no funcionará según UL si no se toman las medidas adecuadas.</p>

2 Instrucciones de seguridad

Instrucciones de seguridad generales

2 Instrucciones de seguridad

2.1 Instrucciones de seguridad generales



¡Peligro!

Si no se observan las siguientes instrucciones básicas de seguridad, pueden ocasionarse serios daños a personas y materiales:

- ▶ Los componentes de accionamiento y automatización de Lenze ...
 - ... sólo deben utilizarse de la manera adecuada.
 - ... nunca deben ponerse en funcionamiento si existen daños visibles.
 - ... nunca deben someterse a modificaciones técnicas.
 - ... nunca deben ponerse en funcionamiento si no están completamente montados.
 - ... nunca deben ponerse en funcionamiento sin las cubiertas necesarias.
 - ... pueden incluir durante y después del funcionamiento, y dependiendo de su grado de protección, piezas vivas, así como móviles y giratorias. Las superficies pueden estar calientes.
- ▶ Observe todas las indicaciones de la documentación adjunta y la documentación correspondiente.

Es requisito esencial para un funcionamiento seguro y sin fallos, así como para lograr las características declaradas del producto.

Las indicaciones técnicas de procedimiento y secciones de conexión presentadas en este documento son propuestas, cuya transferibilidad a la aplicación correspondiente deberá ser comprobada. El fabricante no se hace responsable de la aptitud de los procedimientos y propuestas de conexión que se indican.
- ▶ Todos los trabajos con y en componentes de accionamiento y automatización de Lenze sólo deben ser realizados por personal experto cualificado.

Según IEC 60364 o resp. CENELEC HD 384 se trata de personas, ...

 - ... que conocen la instalación, el montaje, la puesta en marcha y la operación del producto.
 - ... que disponen de las cualificaciones correspondientes a su trabajo.
 - ... que conocen y saben aplicar todas las normas de prevención de accidentes, directivas y leyes aplicables en el lugar de uso.

2.2 Peligros residuales



¡Peligro!

Voltaje eléctrico peligroso

Durante el funcionamiento del equipo básico y **hasta 3 minutos tras la desconexión de la red** las conexiones de la resistencia de frenado pueden mantener una tensión peligrosa.

Posibles consecuencias:

- ▶ Muerte o lesiones graves al entrar en contacto con los bornes de conexión.

Medidas de protección

- ▶ Separar el equipo básico de la red antes de realizar cualquier trabajo en el equipo básico.
- ▶ Comprobar que no haya ningún borne de potencia con tensión.
- ▶ Elegir el lugar de montaje de tal forma que siempre estén garantizadas las condiciones de uso indicadas en los datos técnicos.



¡Peligro!

Superficie caliente durante el funcionamiento

La resistencia de frenado alcanza temperaturas muy altas durante el funcionamiento. (Temperaturas, véanse datos técnicos).

Posibles consecuencias:

- ▶ Fuertes quemaduras al tocar la resistencia de frenado.
- ▶ Fuego o incendio sin llama si se encuentran materiales o sustancias inflamables cerca de la resistencia de frenado o pueden acceder a ella.

Medidas de protección:

- ▶ Antes de trabajar en la resistencia de frenado comprobar la temperatura de la superficie.
- ▶ Elegir el lugar de montaje de forma que las condiciones de uso indicadas en los datos técnicos siempre estén garantizadas.
- ▶ Asegurar el lugar de montaje mediante medidas de protección de incendios y protección contra el contacto.



¡Alto!

Posible sobrecalentamiento de la resistencia de frenado durante el funcionamiento

Debido a una eliminación insuficiente del calor, la resistencia de frenado puede sobrecalentarse durante el funcionamiento.

Posibles consecuencias:

- ▶ La resistencia de frenado puede resultar dañada.
- ▶ El accionamiento no frena y sigue avanzado por inercia hasta parar.

Medidas de protección:

- ▶ Conectar siempre el termocontacto de la resistencia de frenado.
- ▶ Incluir el termocontacto en la monitorización de la instalación de tal manera que en caso de sobrecalentamiento de la resistencia de frenado se desconecte la alimentación de red del equipo básico (p.e. desconectar el control del contactor de red).



Warnings!

Conditions of Acceptability:

- ▶ The product covered by this report is intended for use with Power Conversion Equipment and the like.
- ▶ The devices were tested for horizontal mounting positions. If other mounting positions are necessary in the end use applications, a temperature test shall be performed to ensure the maximum allowed temperature rise.
- ▶ These devices are intended for factory wiring only. The cable lug connector shall be mounted direct on the surface of the copper busbar to provide appropriate connection.
- ▶ Temperature tests have been conducted for continuous duty as indicated in the rating table with closed bottom surface. The heat capability and the maximum temperature rise for higher current ratings at shorter duty cycles shall be determined in the end use.
- ▶ The device were evaluated related to spacings according UL508. The appropriate spacings has to be determined in the end use application. The maximum Voltage rating each element could be max. 1000 V Ac. Therefore the spacing related to UL508 have to be 601-1000 V 14 mm through air and 25.4 mm over surface.
- ▶ The temperature rating of the connection cable shall be at least 105 °C to ensure proper connection.
- ▶ The required wire bending space and the spacings at the terminals after connection shall be determined in the end use application.

3 Descripción del producto

Vista general

3 Descripción del producto

3.1 Vista general

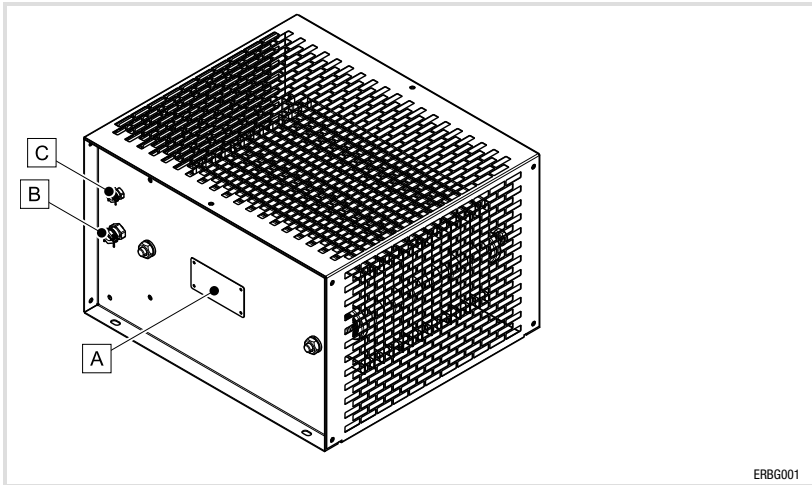

ERBG001

Contenido del suministro

Pos.	Descripción
	Resistencia de frenado
	Instrucciones para el montaje

Elementos de la resistencia de frenado

Pos.	Descripción
A	Placa de características
B	Prensaestopas cable de resistencia de frenado
C	Prensaestopas cable de termocontacto

3.2 Identificación

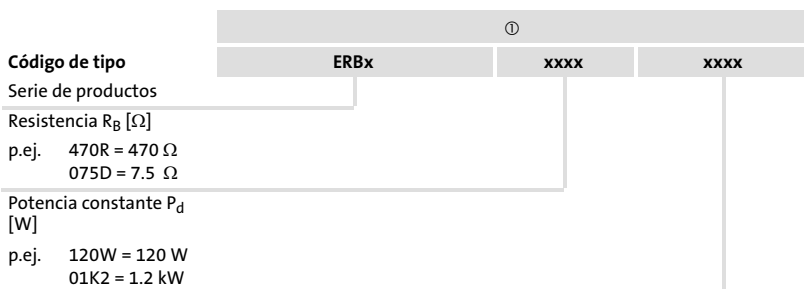
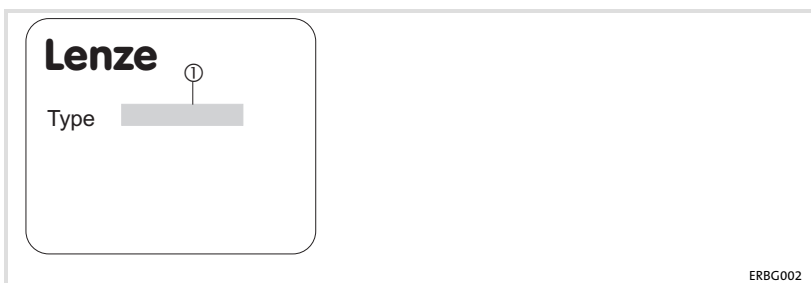

3 Descripción del producto

Uso previsto

3.3 Uso previsto

Las resistencias de frenado

- ▶ sólo deberán utilizarse en las condiciones de uso descritas en este manual.
- ▶ son componentes
 - para ser montados en una máquina.
 - para ser unidos a otros componentes y crear una máquina.

La puesta en marcha de la resistencia de frenado está prohibida hasta que se haya constatado que la máquina en la que se montará la resistencia de frenado cumple con las exigencias de la Directiva de Máquinas CE.

- ▶ son medios de trabajo electrónicos para ser montados en armarios eléctricos o en recintos de trabajo cerrados.
- ▶ cumplen con las exigencias de protección de la Directiva CE "Bajo Voltaje".
- ▶ no son máquinas en el sentido de la Directiva CE de Máquinas.
- ▶ no son electrodomésticos sino que han sido previstos exclusivamente como componentes para ser utilizados para fines industriales.

Sistemas de accionamiento con resistencias de frenado

- ▶ La responsabilidad del cumplimiento con las Directivas CE en la aplicación de la máquina es del usuario.

¡Cualquier otro uso se considerará inadecuado!

3.4 Condiciones del dimensionado

Al utilizar resistencias de frenado observe lo siguiente:

- ▶ Valor promedio de la potencia en modo generador < potencia constante P_d de la resistencia de frenado.
- ▶ Potencia en modo generador durante el tiempo de frenado < cantidad térmica Q_B de la resistencia de frenado.
- ▶ Tiempo de frenado < 10 % del tiempo de ciclo (tiempo de frenado + tiempo de descanso).
- ▶ Conectar siempre el termocontacto para incluirlo así en la monitorización de la instalación, de manera que en caso de sobrecalentamiento de la resistencia de frenado, se desconecte el suministro de red del equipo básico.

En ese momento debe valer: En el intervalo de tiempo $t_{cyc, RB}$ (ciclo de resistencia de frenado) los tiempos de frenado acumulados t_{brk} siempre deben ser \leq que la duración máxima de frenado $t_{brk, máx}$.

Cálculo

Ciclo de resistencia de frenado $t_{cyc, RB}$:

$$t_{cyc, RB} = \frac{Q_B}{P_d} \text{ con}$$

Q_B Cantidad térmica en Ws
 P_d Potencia constante en W

Duración máx. de frenado $t_{brk, máx}$ dentro del intervalo de tiempo $t_{cyc, RB}$:

$$t_{brk, max} = \frac{Q_B \cdot R_B}{U_{max}^2} \text{ con}$$

Q_B Cantidad térmica en Ws
 R_B Resistencia en Ω
 $U_{máx}$ Voltaje operativo máx. en V

Ejemplos para la evaluación de la condición

Se conoce el ciclo de la resistencia de frenado $t_{\text{cyc, RB}} = 150 \text{ s}$ y la duración máx. de frenado $t_{\text{brk, máx}} = 10 \text{ s}$. Los tiempos de frenado t_{brk} y el ciclo de proceso $t_{\text{cyc, Prc}}$ son ejemplos.

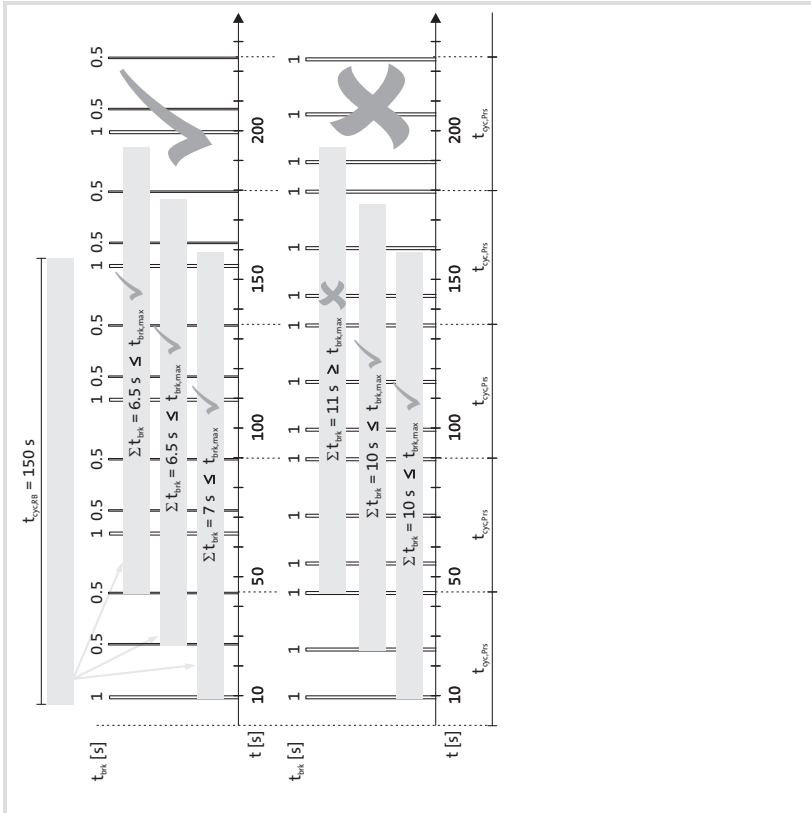

En el ejemplo anterior se mantiene la condición de dimensionado en todo momento. En el siguiente ejemplo las condiciones de dimensionado no se mantienen una vez, es decir que la resistencia de frenado seleccionada no es adecuada para el proceso predeterminado. Utilice una resistencia de frenado con mayor potencia (menor ciclo de resistencia de frenado $t_{\text{cyc, RB}}$).

4 Datos técnicos

4.1 Datos generales y condiciones de uso

Conformidad y aprobación

Conformidad

CE	2006/95/CE	Directiva de Bajo Voltaje	
EAC	TP TC 020/2011 (TR TS 020/2011)	Compatibilidad electromagnética de productos técnicos	Conformidad Eurasiática TR TS: Reglamento Técnico de la Unión Aduanera
EAC	TP TC 004/2011 (TR TS 004/2011)	Acerca de la seguridad de equipos de bajo voltaje	Conformidad Eurasiática TR TS: Reglamento Técnico de la Unión Aduanera

Aprobación

UR	UL508	Industrial Control Equipment, Underwriter Laboratories (File-No. E221095) for USA and Canada	
----	-------	--	--

Protección personal y de equipos

Tipo de protección	EN 60529	IP20	
	NEMA 250	Protección contra el contacto según tipo 1	
Termocontacto			
Versión	NC, 100 °C		
Potencia de ruptura	250 V AC / 2.5 A 110 V AC / 1.6 A		

Condiciones ambientales

Clima

Almacenaje	IEC/EN 60721-3-1	1K3 (-25 ... +60 °C)
Transporte	IEC/EN 60721-3-2	2K3 (-25 ... +70 °C)
Operación	IEC/EN 60721-3-3	3K3 (-10 ... +55 °C) Reducción de corriente de +45 ... +55 °C: 1 %/°C
Altura de montaje		0 ... 4000 m snm 1000 ... 4000 m snm: Reducción de corriente 5 %/1000 m
Resistencia a las sacudidas (9.81 m/s ² = 1 g)	EN 50178, IEC 61800-5-1, Germanischer Lloyd, condiciones generales	Resistente a las aceleraciones hasta 0.7 g

Condiciones de montaje		
Lugar de montaje		<ul style="list-style-type: none"> • El lugar de montaje debe cumplir con las características del equipo indicadas en los "Datos generales". • No deben encontrarse materiales o sustancias inflamables cerca de la resistencia de frenado. • El calor generado por la resistencia de frenado debe eliminarse sin obstáculos.
Posición de montaje		
Estándar		Horizontal, de pie
Variante		Vertical, colgando con conexiones abajo.
Espacios libres para el montaje		
Estándar		arriba > 200 mm lateral > 100 mm
Variante		arriba > 200 mm lateral > 100 mm abajo > 300 mm

4.2 Datos nominales

Datos eléctricos				
	R_B	P_d	Q_B	U_{max}
	[Ω]	[W]	[kWs]	[V _{DC}]
ERBG023D05K6	2.3	5600	840	1000
ERBG028D04K1	2.8	4100	615	
ERBG035D03K3	3.5	3300	495	
ERBG043D03K0	4.3	3000	450	
ERBG005R02K6	5.0	2600	390	
ERBG075D01K9	7.5	1900	285	
ERBG012R01K9	12.0			
ERBG012R05K2		5200	780	
ERBG015R03K3	15.0	3300	495	
ERBG015R06K2		6200	930	
ERBG015R10K0		10000	1500	
ERBG018R04K3		18.0	4300	

R_B Resistencia
 P_d Potencia constante
 Q_B Cantidad térmica
 $U_{m\acute{a}x}$ Voltaje operativo máx.

Temperaturas			
	T_{nom}	T_{TK}	$T_{m\acute{a}x}$
		[°C]	
Interior	390	530	690
En la carcasa	200	240	300
en el límite del espacio libre para el montaje *)	120	160	200

T_{nom} Temperatura máxima con datos nominales
 T_{TK} Temperatura a la cual se activa el termocontacto
 $T_{m\acute{a}x}$ Temperatura máxima en caso de uso indebido
 *) Medido en el aire (pequeño coeficiente de conductividad térmica); cuando se encuentran materiales/sustancias en el límite del espacio libre para el montaje, que podrían calentarse (alto coeficiente de conductividad térmica) la temperatura sigue incrementándose.

4 Datos técnicos

Datos mecánicos

4.3 Datos mecánicos

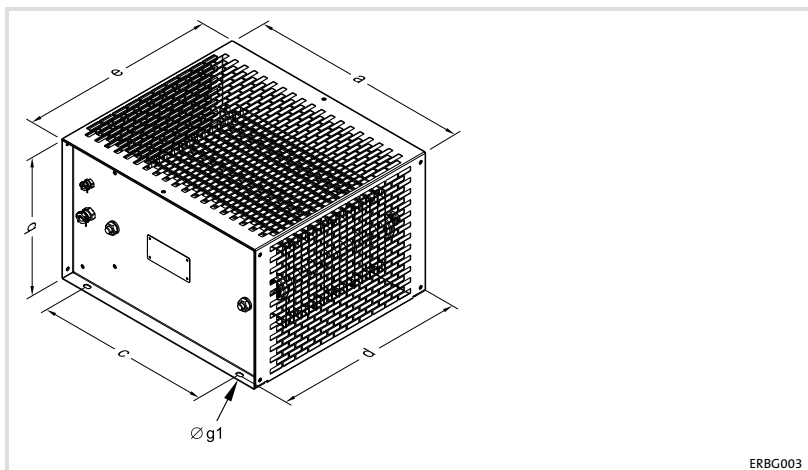

	a	b	c	d	e	g1	
	[mm]						[kg]
ERBG023D05K6	486	302	380	400	426	6.3	15.9
ERBG028D04K1							12.8
ERBG035D03K3							12.6
ERBG043D03K0				300	326		11.8
ERBG005R02K6							11.0
ERBG075D01K9							9.5
ERBG012R01K9				210	236		15.1
ERBG012R05K2							12.6
ERBG015R03K3							17.0
ERBG015R06K2							22.0
ERBG015R10K0							13.5
ERBG018R04K3							400

Espacios libres para el montaje estándar

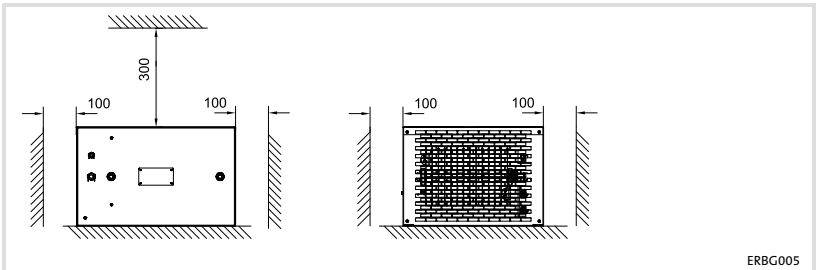

Todas las medidas en milímetros.

Espacios libres para la variante de montaje

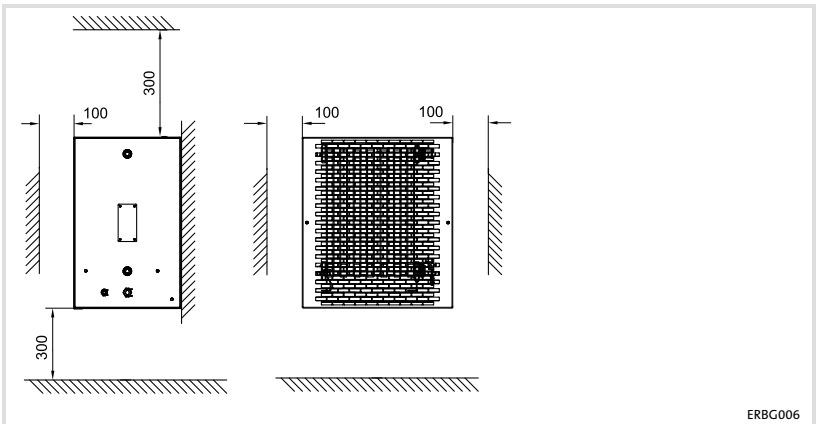

Todas las medidas en milímetros.

5 Instalación mecánica

Pasos para el montaje

5 Instalación mecánica

5.1 Pasos para el montaje

Para montar la resistencia de frenado, proceda de la siguiente manera:

1. Elija un lugar de montaje adecuado.
 - En el lugar de montaje deben estar siempre garantizadas las condiciones de uso indicadas en los datos técnicos. Dado el caso será necesario tomar medidas adicionales.
 - Debe asegurarse una circulación libre del aire para poder eliminar el calor generado.
2. Atornille la resistencia de frenado en el lugar de montaje.
 - Tanto el lugar de montaje como el material de montaje debe asegurar una conexión mecánica duradera.

6 Instalación eléctrica

6.1 Indicaciones importantes



¡Alto!

Posible sobrecalentamiento de la resistencia de frenado durante el funcionamiento

Debido a una eliminación insuficiente del calor, la resistencia de frenado puede sobrecalentarse durante el funcionamiento.

Posibles consecuencias:

- ▶ La resistencia de frenado puede resultar dañada.
- ▶ El accionamiento no frena y sigue avanzado por inercia hasta parar.

Medidas de protección:

- ▶ Conectar siempre el termocontacto de la resistencia de frenado.
- ▶ Incluir el termocontacto en la monitorización de la instalación de tal manera que en caso de sobrecalentamiento de la resistencia de frenado se desconecte la alimentación de red del equipo básico (p.e. desconectar el control del contactor de red).

6.2 Datos de conexión

Conexión	Prensaestopas	Tipo de conexión	Tamaño de conexión	Par de apriete
RB1, RB2 (resistencia de frenado)	M25 / M40 ¹⁾	Terminal de perno	M6	4 Nm 35.4 lb-in
PE (conductor protector)				
T1, T2 (termocontacto)	M16	Regleta de bornes	0.75 ... 1.5 mm ² 18 ... 16 AWG	0.32 Nm 2.85 lb-in

1) ERBG023D05K6, ERBG028D04K1



¡Sugerencia!

La resistencia de frenado tiene dos conexiones PE: una dentro de la carcasa y otra fuera.

- ▶ Si se utiliza un cable con conductor PE para la resistencia de frenado, este deberá pasar a través del prensaestopas con el conductor PE colocado por dentro.
- ▶ Si se utiliza un cable PE separado, se deberá conectar por fuera.

6.3 Esquema de conexiones

Variante 1 (cables cortos)

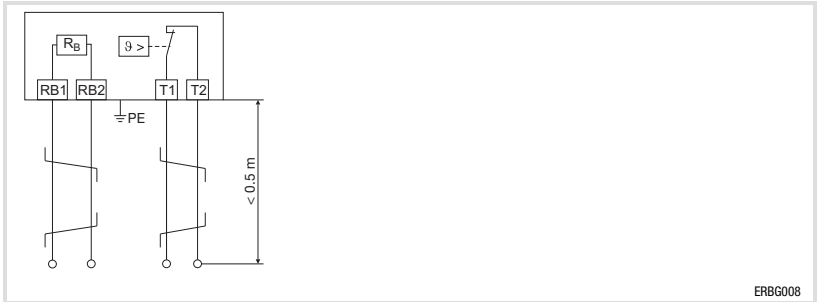

 Cables trenzados

Variante 2 (cables largos)



PES Terminación de malla AF con conexión a PE de gran superficie
 Cables trenzados



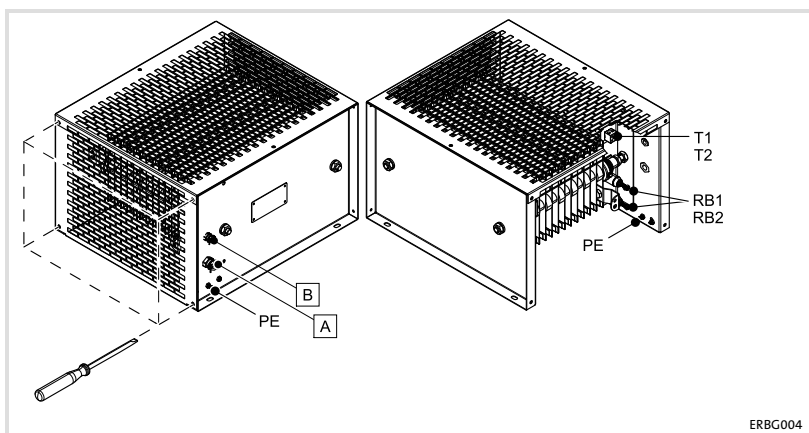

6 Instalación eléctrica

Pasos para el montaje

6.4 Pasos para el montaje



Para conectar la resistencia de frenado proceda de la siguiente manera:

1. Separar equipo básico de la red y comprobar que no hayan bornes de potencia que estén bajo tensión.
2. Desmontar cubierta de los bornes.
3. Colocar cable de la resistencia de frenado:
 - Si la longitud de cable es menor a 0.5 m utilizar cable trenzado (esquema de conexiones variante 1).
 - Si la longitud de cable es menor a 5 m utilizar cable apantallado (esquema de conexiones variante 2).
 - Pasar el cable por el prensaestopas .
 - Colocar conductores en el los conectores RB1, RB2 y PE de la resistencia de frenado, tener cuenta par de apriete. Ejecutar conexión PE según la norma EN 61800-5-1.
 - Apretar prensaestopas .
 - Para cables apantallados: la malla debe estar unida al prensaestopas con gran superficie.
 - Conectar conductores y malla al equipo básico, observando siempre las indicaciones de la documentación del equipo básico.
4. Colocar cables del termocontacto:
 - Utilizar cable trenzado.
 - Pasar cable por el prensaestopas .
 - Conectar conductores a los conectores T1 y T2 de la resistencia de frenado, observando siempre el par de apriete.
 - Apretar prensaestopas .
 - Conectar el termocontacto a la monitorización de la instalación, de forma que en caso de sobrecalentamiento de la resistencia de frenado se desconecte la alimentación de red.
5. Montar cubierta de los bornes.



¡Aviso!

Después del primer encendido y también después de un rato de no utilizarse puede desprender cierto olor y producir un hilo de humo fino, procedente de la resistencia del frenado. Sin embargo, esto es inofensivo.

7 **Mantenimiento**

7.1 **Intervalos de mantenimiento**

La resistencia de frenado no precisa de mantenimiento. Sin embargo se deberá realizar una inspección visual regular a intervalos suficientemente cortos teniendo en cuenta las condiciones del entorno.

Se ha de controlar lo siguiente:

- ▶ El entorno de la resistencia de frenado sigue cumpliendo con las condiciones de uso indicadas en los datos técnicos.
- ▶ Hay polvo o suciedad que impida la eliminación del calor de la resistencia de frenado.
- ▶ Las uniones mecánicas y eléctricas están en buen estado.

7.2 **Trabajos de mantenimiento**

Limpiar resistencia de frenado

1. Separar el equipo básico de la red y esperar por lo menos 3 minutos.
2. Comprobar la temperatura de la resistencia de frenado y dado el caso dejarla enfriar.
3. Comprobar que las conexiones de la resistencia de frenado estén libres de voltaje.
4. Limpiar la resistencia de frenado sin detergentes.

1	Informazioni sul manuale	108
1.1	Informazioni sulla validità	108
1.2	A chi è rivolto	108
1.3	Cronologia del documento	108
1.4	Convenzioni utilizzate	109
1.5	Avvertenze utilizzate	110
2	Informazioni sulla sicurezza	112
2.1	Note di sicurezza generali	112
2.2	Altri pericoli	113
3	Descrizione del prodotto	116
3.1	Panoramica	116
3.2	Identificazione	117
3.3	Utilizzo conforme	118
3.4	Condizioni di impiego	119
4	Dati tecnici	121
4.1	Dati generali e condizioni di impiego	121
4.2	Dati nominali	123
4.3	Dati meccanici	124
5	Installazione meccanica	126
5.1	Procedura di montaggio	126
6	Installazione elettrica	127
6.1	Note importanti	127
6.2	Dati di collegamento	128
6.3	Schema di collegamento	129
6.4	Procedura di montaggio	130
7	Manutenzione	132
7.1	Intervali di manutenzione	132
7.2	Interventi di manutenzione	132

1 Informazioni sul manuale

Informazioni sulla validità

1 Informazioni sul manuale

1.1 Informazioni sulla validità

La presente documentazione è valida per

- ▶ Resistenze di frenatura ERBGxxxxxxx

1.2 A chi è rivolto

La presente documentazione si rivolge al personale tecnico specializzato secondo la norma IEC 60364.

Per personale tecnico qualificato si intendono persone dotate delle necessarie qualifiche per lo svolgimento delle attività di preparazione, montaggio, messa in servizio e funzionamento del prodotto.



Suggerimento:







Per informazioni e ausili sui prodotti Lenze, consultare l'area Download all'indirizzo

www.lenze.com

1.3 Cronologia del documento

Numero documento	Versione			Descrizione
13474656	8.0	10/2014	TD29	Avvertenze UL in lingua francese per il Canada Conformità EAC Correzioni generali
13314940	7.0	01/2011	TD29	Revisione

1.4 Convenzioni utilizzate

Tipo di informazione	Convenzione tipografica	Esempi/Note
Modalità di scrittura dei numeri		
Separatore decimali	Punto	Si utilizza in generale il punto come separatore dei decimali. Esempio: 1234.56
Avvertenze		
Avvertenze UL		Vengono riportate in inglese e francese.
Avvertenze UR		
Evidenziazioni nel testo		
Nome di programma	» «	Software per PC Ad esempio: »Engineer«, »Global Drive Control« (GDC)
Simboli		
Riferimento a una pagina		Riferimento ad un'altra pagina contenente informazioni aggiuntive Ad esempio:  16 = vedere pagina 16
Riferimento ad altra documentazione		Riferimento ad altra documentazione contenente informazioni aggiuntive Ad esempio:  EDKxxx = vedere il documento EDKxxx

1 Informazioni sul manuale

Avvertenze utilizzate

1.5 Avvertenze utilizzate

Per segnalare pericoli ed informazioni importanti, nella presente documentazione sono riportati i seguenti simboli e parole di segnalazione:

Note di sicurezza

Struttura delle note di sicurezza:





Pericolo!



(indica il tipo e la gravità del pericolo)

Testo della nota



(descrive il pericolo e fornisce indicazioni su come può essere evitato)

Simbolo e parola di segnalazione	Significato
 Pericolo!	Pericolo di danni alle persone dovuti a tensione elettrica Segnala una situazione di pericolo che può provocare morte o gravi lesioni se non vengono osservate le necessarie misure precauzionali.
 Pericolo!	Pericolo di danni alle persone dovuti a una fonte generica di pericolo Segnala una situazione di pericolo che può provocare morte o gravi lesioni se non vengono osservate le necessarie misure precauzionali.
 Stop!	Pericolo di danni materiali Segnala un possibile pericolo che può provocare danni materiali se non vengono osservate le necessarie misure precauzionali.

Note di utilizzo

Simbolo e parola di segnalazione	Significato
 Avvertenza:	Avvertenza importante per assicurare un corretto funzionamento dell'apparecchiatura
 Suggerimento:	Utile suggerimento per un più semplice utilizzo
	Rimando ad altra documentazione

Note di sicurezza e istruzioni d'uso speciali per UL e UR

Simbolo e parola di segnalazione	Significato
 Warnings!	<p>Nota di sicurezza o istruzioni d'uso per il funzionamento di un dispositivo con omologazione UL in impianti omologati UL.</p> <p>Il funzionamento del sistema azionamento probabilmente non sarà conforme alla normativa UL, a meno che non vengano prese le necessarie misure a tal fine.</p>
 Warnings!	<p>Nota di sicurezza o istruzioni d'uso per il funzionamento di un dispositivo con omologazione UR in impianti omologati UL.</p> <p>Il funzionamento del sistema azionamento probabilmente non sarà conforme alla normativa UL, a meno che non vengano prese le necessarie misure a tal fine.</p>

2 Informazioni sulla sicurezza

Note di sicurezza generali

2 Informazioni sulla sicurezza

2.1 Note di sicurezza generali



Pericolo!

La mancata osservanza delle seguenti misure fondamentali di sicurezza può provocare gravi danni a persone e cose.

- ▶ Relativamente ai componenti di azionamento e automazione Lenze, osservare quanto segue:
 - utilizzare tali componenti esclusivamente in conformità agli usi preposti
 - non mettere mai in funzione tali componenti in caso di danni evidenti
 - non effettuare in nessun caso modifiche tecniche
 - non mettere mai in funzione tali componenti in caso di montaggio incompleto
 - non azionare mai tali componenti senza le coperture richieste
 - in funzione del grado di protezione, durante o dopo il funzionamento tali componenti possono presentare parti sotto tensione, mobili o rotanti; le superfici possono essere ustionanti.
- ▶ Osservare tutte le istruzioni e avvertenze fornite nella documentazione in dotazione e pertinenti.

Solo in questo modo è possibile assicurare un funzionamento sicuro e senza problemi, nonché caratteristiche del prodotto conformi alle specifiche. Le specifiche, le procedure e gli schemi di collegamento forniti nel presente documento sono suggerimenti per i quali è necessario verificare l'applicabilità al singolo caso. Il produttore non si assume alcuna responsabilità per l'idoneità delle procedure e degli schemi di collegamento proposti.
- ▶ Tutti gli interventi relativi ai componenti di azionamento e automazione Lenze devono essere eseguiti esclusivamente da personale specializzato qualificato.

Secondo la normativa IEC 60364, ovvero CENELEC HD 384, per personale qualificato si intende:

 - personale che ha acquisito familiarità con l'installazione, il montaggio, la messa in servizio e il funzionamento del prodotto;
 - personale che dispone delle necessarie qualifiche grazie all'esperienza maturata;
 - personale che conosce ed è in grado di applicare tutte le disposizioni antinfortunistiche, le direttive e le norme vigenti nel luogo di installazione.

2.2 Altri pericoli

**Pericolo!****Tensione elettrica pericolosa**

Durante il funzionamento del modulo asse e **fino a 3 minuti dopo la disinserzione dalla rete** possono permanere tensioni elettriche pericolose sui collegamenti della resistenza di frenatura.

Possibili conseguenze:

- ▶ Morte o lesioni gravi in caso di contatto con i morsetti di collegamento.

Misure di protezione:

- ▶ Prima di eseguire interventi sulla resistenza di frenatura, disinserire l'alimentazione del modulo asse.
- ▶ Verificare l'assenza di tensione su tutti i morsetti di potenza.
- ▶ Scegliere un luogo di montaggio idoneo, in modo che siano sempre garantite le condizioni di impiego specificate nei Dati tecnici.

**Pericolo!****Superficie ustionante durante il funzionamento**

Durante il funzionamento la resistenza di frenatura si surriscalda (per le temperature, vedere i dati tecnici).

Possibili conseguenze:

- ▶ Gravi ustioni in caso di contatto con la resistenza di frenatura.
- ▶ Incendio o combustione senza fiamma qualora nelle vicinanze della resistenza di frenatura si trovino o possano finire materiali o sostanze infiammabili.

Misure di protezione:

- ▶ Prima di eseguire interventi sulla resistenza di frenatura, verificare la temperatura delle sue superfici.
- ▶ Selezionare il luogo di montaggio in modo che siano sempre assicurate le condizioni di impiego specificate nei dati tecnici.
- ▶ Proteggere il luogo di montaggio con misure antincendio appropriate e una protezione da contatto.

**Stop!****Possibile surriscaldamento della resistenza di frenatura durante il funzionamento**

A causa di una dissipazione del calore insufficiente, la resistenza di frenatura può surriscaldarsi durante il funzionamento.

Possibili conseguenze:

- ▶ Distruzione della resistenza di frenatura.
- ▶ Mancata frenatura dell'azionamento che continua a girare per inerzia.

Misure di protezione:

- ▶ Collegare sempre il termocontatto della resistenza di frenatura.
- ▶ Collegare il termocontatto nel circuito di sorveglianza dell'impianto in modo che in caso di surriscaldamento della resistenza di frenatura l'alimentazione del dispositivo base venga disinserita (ad es. disinserzione del controllo contattori di rete).



Warnings!

Conditions of Acceptability:

- ▶ The product covered by this report is intended for use with Power Conversion Equipment and the like.
- ▶ The devices were tested for horizontal mounting positions. If other mounting positions are necessary in the end use applications, a temperature test shall be performed to ensure the maximum allowed temperature rise.
- ▶ These devices are intended for factory wiring only. The cable lug connector shall be mounted direct on the surface of the copper busbar to provide appropriate connection.
- ▶ Temperature tests have been conducted for continuous duty as indicated in the rating table with closed bottom surface. The heat capability and the maximum temperature rise for higher current ratings at shorter duty cycles shall be determined in the end use.
- ▶ The device were evaluated related to spacings according UL508. The appropriate spacings has to be determined in the end use application. The maximum Voltage rating each element could be max. 1000 V Ac. Therefore the spacing related to UL508 have to be 601-1000 V 14 mm through air and 25.4 mm over surface.
- ▶ The temperature rating of the connection cable shall be at least 105 °C to ensure proper connection.
- ▶ The required wire bending space and the spacings at the terminals after connection shall be determined in the end use application.

3 Descrizione del prodotto

Panoramica

3 Descrizione del prodotto

3.1 Panoramica

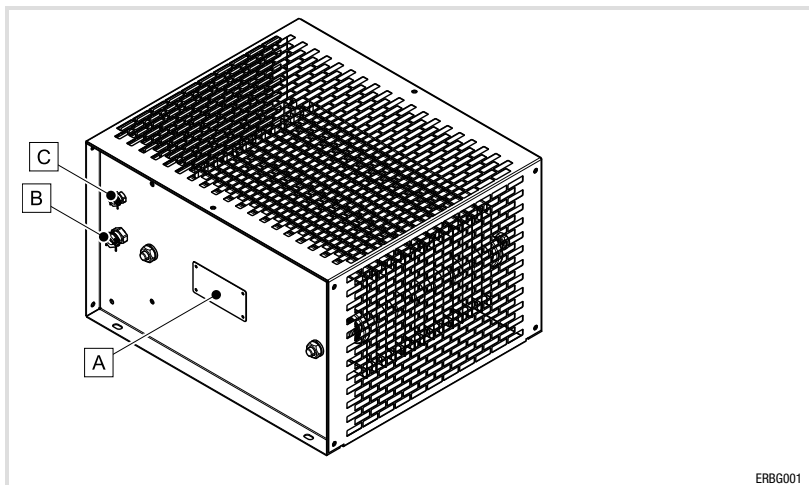

Oggetto della fornitura

Pos.	Descrizione
	Resistenza di frenatura
	Istruzioni di montaggio

Elementi sulla resistenza di frenatura

Pos.	Descrizione
A	Targhetta
B	Pressacavo resistenza di frenatura
C	Pressacavo termocontatto

3.2 Identificazione

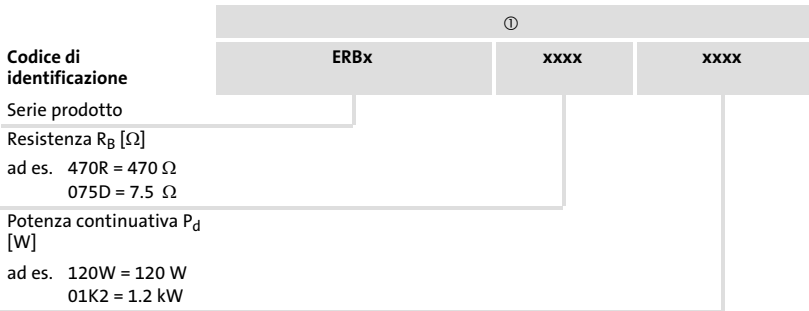

3 Descrizione del prodotto

Utilizzo conforme

3.3 Utilizzo conforme

Le resistenze di frenatura

- ▶ devono essere utilizzate solo alle condizioni di impiego descritte nel presente manuale;
- ▶ sono componenti
 - per l'integrazione in una macchina
 - per l'assemblaggio con altri componenti in una macchina;

La messa in servizio della resistenza di frenatura non può essere effettuata finché non sia stata appurata la conformità della macchina in cui è installata la resistenza di frenatura alle disposizioni della Direttiva Macchine CE.

- ▶ sono apparecchiature elettriche progettate per il montaggio in armadi elettrici o analoghe strutture chiuse;
- ▶ sono conformi ai requisiti di protezione della Direttiva CE "Bassa Tensione";
- ▶ non sono macchine ai sensi della Direttiva Macchine CE;
- ▶ non sono da utilizzarsi come apparecchiature domestiche, ma esclusivamente per impieghi industriali o professionali.

Sistemi di azionamento con resistenze di frenatura

- ▶ È responsabilità del riutilizzatore assicurare la conformità alle Direttive CE nell'uso della macchina.

Ogni altro utilizzo è considerato indebito.

3.4 Condizioni di impiego

Quando si utilizzano resistenze di frenatura, prestare attenzione a quanto segue:

- ▶ Valore medio della potenza rigenerativa < potenza continuativa P_d della resistenza di frenatura.
- ▶ Potenza rigenerativa nel tempo di frenatura < quantità di calore Q_B della resistenza di frenatura.
- ▶ Tempo di frenatura < 10 % del tempo di ciclo (tempo di frenatura + pausa).
- ▶ Collegare sempre il termocontatto integrandolo nel sistema di sorveglianza dell'impianto in modo che in caso di surriscaldamento della resistenza di frenatura l'alimentazione di rete del dispositivo base venga disinserita.

In ogni momento deve essere rispettato quanto segue: nell'intervallo di tempo $t_{cyc, RB}$ (ciclo della resistenza di frenatura) i tempi di frenatura accumulati t_{brk} devono sempre essere \leq alla durata di frenatura massima $t_{brk, max}$.

Calcolo

Ciclo resistenza di frenatura $t_{cyc, RB}$:

$$t_{cyc, RB} = \frac{Q_B}{P_d} \text{ con}$$

Q_B Quantità di calore in Ws
 P_d Potenza continuativa in W

Durata di frenatura max. $t_{brk, max}$ nell'intervallo di tempo $t_{cyc, RB}$:

$$t_{brk, max} = \frac{Q_B \cdot R_B}{U_{max}^2} \text{ con}$$

Q_B Quantità di calore in Ws
 R_B Resistenza in Ω
 U_{max} Tensione d'esercizio max. in V

Esempi di valutazione delle condizioni

I valori dati sono il ciclo della resistenza di frenatura $t_{\text{cyc, RB}} = 150 \text{ s}$ e la durata max. di frenatura $t_{\text{brk, max}} = 10 \text{ s}$. I tempi di frenatura t_{brk} e il ciclo di processo $t_{\text{cyc, Prc}}$ sono riportati a titolo di esempio.

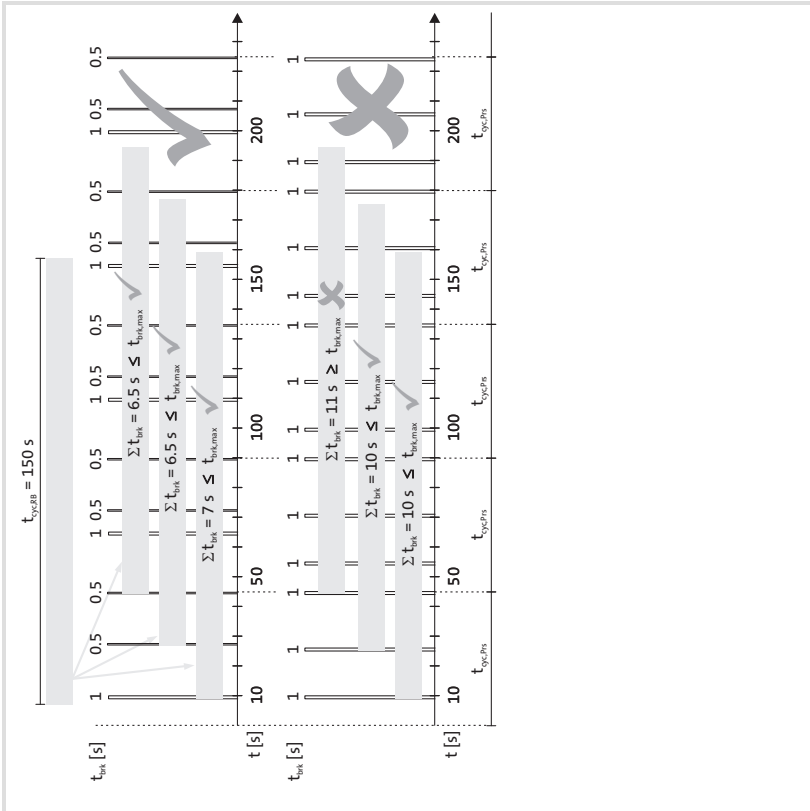

Nell'esempio sopra, le condizioni di impiego vengono rispettate in ogni momento. Nell'esempio sotto, invece, tali condizioni una volta non vengono rispettate, cioè la resistenza di frenatura selezionata non è idonea per il processo. In questo caso deve essere utilizzata una resistenza di frenatura con una potenza maggiore (ciclo della resistenza di frenatura $t_{\text{cyc, RB}}$ più breve).

4 Dati tecnici

4.1 Dati generali e condizioni di impiego

Conformità e omologazioni

Conformità

CE	2006/95/CE	Direttiva Bassa Tensione	
EAC	TP TC 020/2011 (TR ZU 020/2011)	Compatibilità elettromagnetica degli apparecchi tecnici	Conformità euroasiatica TR ZU: Regolamento tecnico dell'unione doganale
EAC	TP TC 004/2011 (TR ZU 004/2011)	Informazioni sulla sicurezza dei dispositivi a bassa tensione	Conformità euroasiatica TR ZU: Regolamento tecnico dell'unione doganale

Omologazione

UR	UL508	Industrial Control Equipment, Underwriter Laboratories (File-No. E221095) per USA e Canada	
----	-------	--	--

Protezione delle persone e protezione del dispositivo

Grado di protezione	EN 60529	IP20	
	NEMA 250	Protezione da contatto secondo Tipo 1	
Termocontatto			
Esecuzione	Contatto NC, 100 °C		
Potere di interruzione	250 V AC / 2.5 A 110 V AC / 1.6 A		

Condizioni ambientali

Condizioni climatiche

Stoccaggio	IEC/EN 60721-3-1	1K3 (-25 ... +60 °C)
Trasporto	IEC/EN 60721-3-2	2K3 (-25 ... +70 °C)
Funzionamento	IEC/EN 60721-3-3	3K3 (-10 ... +55 °C) Riduzione di corrente da +45 a +55 °C: 1 %/°C
Altitudine di installazione		0 ... 4000 m s.l.m. 1000 ... 4000 m s.l.m.: riduzione di corrente 5 %/1000 m
Resistenza alle vibrazioni (9.81 m/s ² = 1 g)	EN 50178, IEC 61800-5-1, Germanischer Lloyd, condizioni generali	Resistente all'accelerazione fino a 0.7 g

Condizioni di montaggio		
Luogo di montaggio		<ul style="list-style-type: none"> • Il luogo di montaggio deve essere conforme alle caratteristiche del dispositivo specificate nella sezione "Dati generali". • Nelle vicinanze della resistenza di frenatura non devono trovarsi oggetti o materiali infiammabili. • Il calore generato dalla resistenza di frenatura deve essere dissipato senza ostacoli.
Posizione di montaggio		
Standard		In orizzontale
Variante		In verticale con collegamenti sotto.
Quote di rispetto		
Standard		sopra > 200 mm a lato > 100 mm
Variante		sopra > 200 mm a lato > 100 mm sotto > 300 mm

4.2 Dati nominali

Dati elettrici				
	R_B	P_d	Q_B	U_{max}
	[Ω]	[W]	[kWs]	[V _{DC}]
ERBG023D05K6	2.3	5600	840	1000
ERBG028D04K1	2.8	4100	615	
ERBG035D03K3	3.5	3300	495	
ERBG043D03K0	4.3	3000	450	
ERBG005R02K6	5.0	2600	390	
ERBG075D01K9	7.5	1900	285	
ERBG012R01K9	12.0			
ERBG012R05K2		5200	780	
ERBG015R03K3	15.0	3300	495	
ERBG015R06K2		6200	930	
ERBG015R10K0		10000	1500	
ERBG018R04K3		18.0	4300	

R_B Resistenza
 P_d Potenza continuativa
 Q_B Quantità di calore
 U_{max} Tensione d'esercizio max.

Temperature			
	T_{nom}	T_{TK}	T_{max}
		[°C]	
Interna	390	530	690
Su custodia	200	240	300
sul bordo libero di montaggio *)	120	160	200

T_{nom} Temperatura massima ai dati nominali
 T_{TK} Temperatura con termocontatto attivato
 T_{max} Temperatura massima in caso di utilizzo improprio
 *) Misurata nel mezzo ambientale aria (bassa conducibilità termica); se attorno alle aree di rispetto sono presenti sostanze/materiali che possono riscaldarsi (elevata conducibilità termica), la temperatura continua ad aumentare.

4 Dati tecnici

Dati meccanici

4.3 Dati meccanici

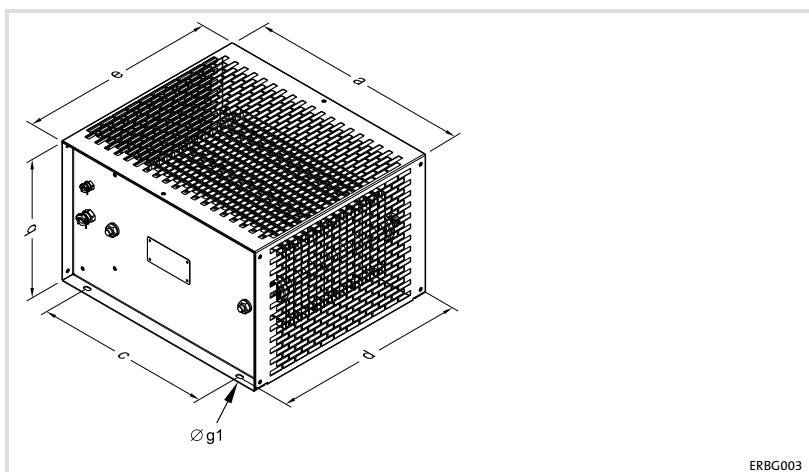

	a	b	c	d	e	g1	 [kg]
	[mm]						
ERBG023D05K6	486	302	380	400	426	6.3	15.9
ERBG028D04K1							12.8
ERBG035D03K3							12.6
ERBG043D03K0				300	326		11.8
ERBG005R02K6							11.0
ERBG075D01K9							9.5
ERBG012R01K9				400	426		15.1
ERBG012R05K2							12.6
ERBG015R03K3							17.0
ERBG015R06K2							22.0
ERBG015R10K0							22.0
ERBG018R04K3							13.5

Quote di rispetto richieste per il montaggio standard

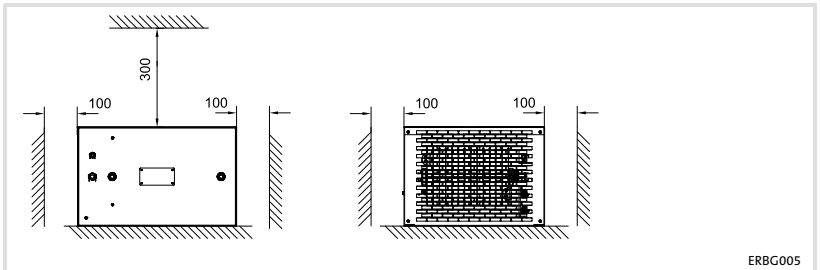

Tutte le quote sono in millimetri.

Quote di rispetto richieste per la variante di montaggio (orizzontale)

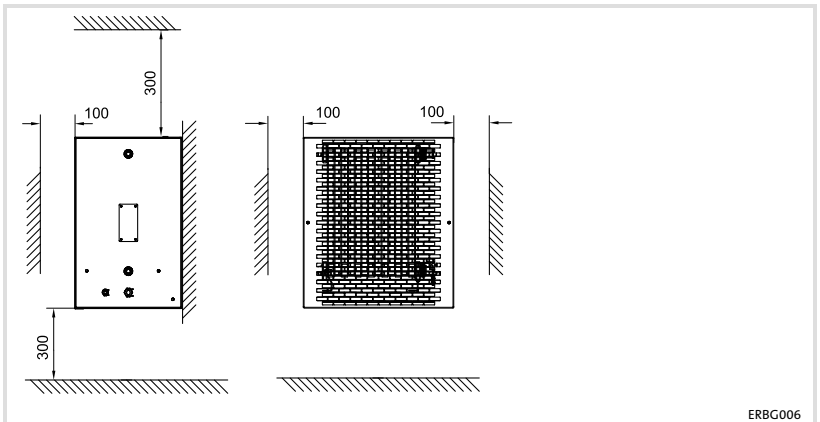

Tutte le quote sono in millimetri.

5 Installazione meccanica

Procedura di montaggio

5 Installazione meccanica

5.1 Procedura di montaggio

Per montare la resistenza di frenatura, procedere come segue:

1. Selezionare un'ubicazione idonea per il montaggio.
 - Il luogo di montaggio prescelto deve sempre garantire le condizioni di impiego specificate nei Dati tecnici; in caso contrario, adottare misure aggiuntive.
 - Per un'efficace dissipazione del calore, occorre assicurare che la circolazione dell'aria non sia ostacolata.
2. Fissare con viti la resistenza di frenatura nella posizione di montaggio.
 - La posizione ed i componenti di montaggio devono garantire una connessione meccanica stabile.

6 Installazione elettrica

6.1 Note importanti



Stop!

Possibile surriscaldamento della resistenza di frenatura durante il funzionamento

A causa di una dissipazione del calore insufficiente, la resistenza di frenatura può surriscaldarsi durante il funzionamento.

Possibili conseguenze:

- ▶ Distruzione della resistenza di frenatura.
- ▶ Mancata frenatura dell'azionamento che continua a girare per inerzia.

Misure di protezione:

- ▶ Collegare sempre il termocontatto della resistenza di frenatura.
- ▶ Collegare il termocontatto nel circuito di sorveglianza dell'impianto in modo che in caso di surriscaldamento della resistenza di frenatura l'alimentazione del dispositivo base venga disinserita (ad es. disinserzione del controllo contattori di rete).

6.2 Dati di collegamento

Collegamento	Pressacavo	Tipo di collegamento	Dimensione	Coppia di serraggio
RB1, RB2 (resistenza di frenatura)	M25 / M40 ¹⁾	Collegamento a perno	M6	4 Nm 35.4 lb-in
PE (conduttore di protezione)				
T1, T2 (termocontatto)	M16	Collegamento a bussola	0.75 ... 1.5 mm ² 18 ... 16 AWG	0.32 Nm 2.85 lb-in

¹⁾ ERBG023D05K6, ERBG028D04K1



Suggerimento:

La resistenza di frenatura è dotata di due collegamenti PE, uno all'interno della carcassa e l'altro all'esterno.

- ▶ Quando si utilizza un cavo con conduttore PE per la resistenza di frenatura, fare passare il cavo attraverso il pressacavo e fissare internamente il conduttore PE.
- ▶ Se si utilizza un cavo PE separato, collegarlo esternamente.

6.3 Schema di collegamento

Variante 1: senza prolungamento dei cavi





ERBG008

 Cavi intrecciati

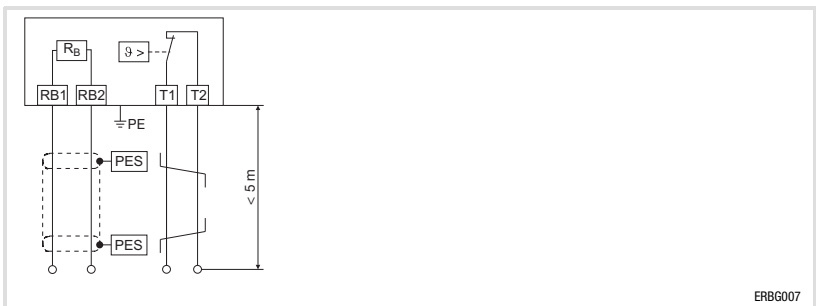
Variante 2: con prolungamento dei cavi



ERBG007

 Schermatura HF con collegamento a PE ad ampia superficie
 Cavi intrecciati



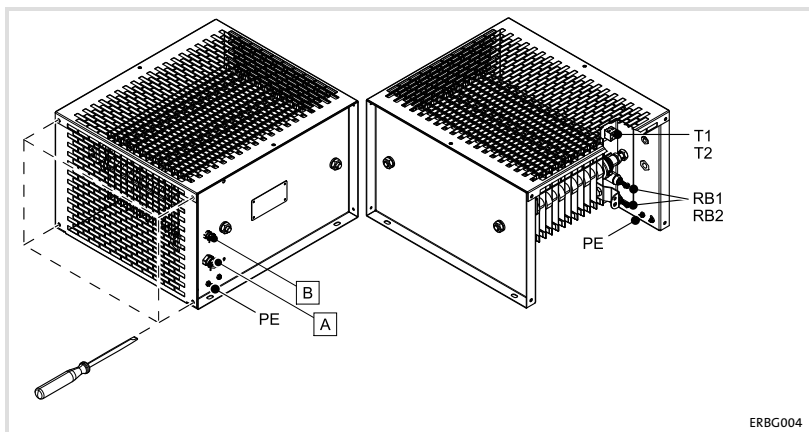

6 Installazione elettrica

Procedura di montaggio

6.4 Procedura di montaggio



Per collegare la resistenza di frenatura, procedere come segue:

1. Disinserire l'alimentazione del modulo asse e verificare l'assenza di tensione su tutti i morsetti di potenza.
2. Smontare il coperchio della morsettiera.
3. Collegare la resistenza di frenatura:
 - Per lunghezze fino a 0.5 m, utilizzare un cavo intrecciato (schema di collegamento variante 1).
 - Per lunghezze fino a 5 m, utilizzare un cavo schermato (schema di collegamento variante 2).
 - Tirare il cavo attraverso il pressacavo .
 - Collegare i conduttori sulla resistenza di frenatura a RB1, RB2 e PE, applicando la coppia di serraggio specificata. Eseguire il collegamento PE secondo EN 61800-5-1.
 - Stringere il pressacavo .
Per cavo schermato: la schermatura deve essere saldamente collegata al pressacavo con una superficie il più ampia possibile.
 - Collegare i conduttori e la schermatura sul modulo asse, seguendo le indicazioni fornite nella documentazione relativa al modulo asse.
4. Collegare il termocontatto:
 - Utilizzare un cavo intrecciato.
 - Tirare il cavo attraverso il pressacavo .
 - Collegare i conduttori sulla resistenza di frenatura a T1 e T2, applicando la coppia di serraggio specificata.
 - Stringere il pressacavo .
 - Integrare il termocontatto nel sistema di sorveglianza dell'impianto in modo che in caso di surriscaldamento della resistenza di frenatura venga automaticamente disinserita l'alimentazione di rete.
5. Montare il coperchio della morsettiera.



Avvertenza:

Dopo la prima inserzione ed eventualmente dopo un periodo di inutilizzo prolungato, è possibile che dalla resistenza di frenatura si sviluppi un cattivo odore, associato a un leggero fumo. Non è nulla di pericoloso.

7 **Manutenzione**

Intervalli di manutenzione

7 **Manutenzione**

7.1 **Intervalli di manutenzione**

La resistenza di frenatura non richiede manutenzione. Si raccomanda, tuttavia, di eseguire un controllo visivo ad intervalli regolari, con una frequenza ritenuta idonea in considerazione delle condizioni ambientali.

Controllare quanto segue:

- ▶ Conformità dell'ambiente di installazione della resistenza di frenatura con le condizioni di impiego specificate nei Dati tecnici
- ▶ Assenza di polvere o sporco che ostruisca il dissipatore di calore della resistenza di frenatura
- ▶ Integrità dei collegamenti meccanici ed elettrici.

7.2 **Interventi di manutenzione**

Pulizia della resistenza di frenatura

1. Disinserire l'alimentazione del dispositivo base ed attendere almeno 3 minuti.
2. Controllare la temperatura della resistenza di frenatura e se necessario lasciarla raffreddare.
3. Controllare i collegamenti della resistenza di frenatura ed accertare che non vi sia tensione.
4. Pulire la resistenza di frenatura senza utilizzare detersivi.



© 10/2014



Lenze Automation GmbH
Postfach 10 13 52, D-31763 Hameln
Hans-Lenze-Str. 1, D-31855 Aerzen
Germany



+49 5154 82-0



+49 5154 82-2800



lenze@lenze.com



www.lenze.com



Service Lenze Service GmbH
Breslauer Straße 3, D-32699 Extertal

Germany



008000 2446877 (24 h helpline)



+49 5154 82-1112



service@lenze.com

EDKRBG018R ■ 13474656 ■ DE/EN/FR/ES/IT ■ 8.0 ■ TD29

10 9 8 7 6 5 4 3 2 1